



Agilent InfinityLab LC Series 1260 Infinity II Isocratic- and Quaternary Pumps

User Manual



Agilent Technologies

Notices

© Agilent Technologies, Inc. 2016

No part of this manual may be reproduced in any form or by any means (including electronic storage and retrieval or translation into a foreign language) without prior agreement and written consent from Agilent Technologies, Inc. as governed by United States and international copyright laws.

Manual Part Number

G7111-90000

Edition

04/2016

Printed in Germany

Agilent Technologies
Hewlett-Packard-Strasse 8
76337 Waldbronn

Warranty

The material contained in this document is provided “as is,” and is subject to being changed, without notice, in future editions. Further, to the maximum extent permitted by applicable law, Agilent disclaims all warranties, either express or implied, with regard to this manual and any information contained herein, including but not limited to the implied warranties of merchantability and fitness for a particular purpose. Agilent shall not be liable for errors or for incidental or consequential damages in connection with the furnishing, use, or performance of this document or of any information contained herein. Should Agilent and the user have a separate written agreement with warranty terms covering the material in this document that conflict with these terms, the warranty terms in the separate agreement shall control.

Technology Licenses

The hardware and/or software described in this document are furnished under a license and may be used or copied only in accordance with the terms of such license.

Restricted Rights Legend

If software is for use in the performance of a U.S. Government prime contract or subcontract, Software is delivered and licensed as “Commercial computer software” as defined in DFAR 252.227-7014 (June 1995), or as a “commercial item” as defined in FAR 2.101(a) or as “Restricted computer software” as defined in FAR 52.227-19 (June 1987) or any equivalent agency regulation or contract clause. Use, duplication or disclosure of Software is subject to Agilent Technologies’ standard commercial license terms, and non-DOD Departments and Agencies of the U.S. Government will

receive no greater than Restricted Rights as defined in FAR 52.227-19(c)(1-2) (June 1987). U.S. Government users will receive no greater than Limited Rights as defined in FAR 52.227-14 (June 1987) or DFAR 252.227-7015 (b)(2) (November 1995), as applicable in any technical data.

Safety Notices

CAUTION

A **CAUTION** notice denotes a hazard. It calls attention to an operating procedure, practice, or the like that, if not correctly performed or adhered to, could result in damage to the product or loss of important data. Do not proceed beyond a **CAUTION** notice until the indicated conditions are fully understood and met.

WARNING

A **WARNING** notice denotes a hazard. It calls attention to an operating procedure, practice, or the like that, if not correctly performed or adhered to, could result in personal injury or death. Do not proceed beyond a **WARNING** notice until the indicated conditions are fully understood and met.

In This Guide...

This manual covers:

- Agilent 1260 Infinity II Isocratic Pump (G7110B),
- Agilent 1260 Infinity II Quaternary Pump VL (G7111A),
- Agilent 1260 Infinity II Quaternary Pump (G7111B), and
- Agilent 1260 Infinity II Bio-inert Pump (G5654A).

1 Introduction

This chapter gives an introduction to the module, instrument overview and internal connectors.

2 Site Requirements and Specifications

This chapter provides information on environmental requirements, physical and performance specifications.

3 Using the Pump

This chapter provides information for optimized usage of the module.

4 Optimizing Performance

This chapter gives hints on how to optimize the performance or use additional devices.

5 Troubleshooting and Diagnostics

This chapter gives an overview about the troubleshooting and diagnostic features and the different user interfaces.

6 Error Information

This chapter describes the meaning of error messages, and provides information on probable causes and suggested actions how to recover from error conditions.

In This Guide...

7 Test Functions and Calibration

This chapter describes the tests for the module.

8 Maintenance

This chapter describes the maintenance of the module.

9 Parts for Maintenance

This chapter provides information on parts for maintenance.

10 Identifying Cables

This chapter provides information on cables used with the Agilent 1200 Infinity Series modules.

11 Hardware Information

This chapter describes the pump in more detail on hardware and electronics.

12 LAN Configuration

This chapter provides information on connecting the module to the Agilent ChemStation PC.

13 Appendix

This chapter provides addition information on safety, legal and web.

Contents

1	Introduction	9
	Introduction to the Pump	10
	G7110B Isocratic Pump	11
	G7111A Quaternary Pump VL	13
	G7111B Quaternary Pump	15
	G5654A Bio-inert Pump	17
	Overview of the Hydraulic Path	19
	Leak and Waste Handling	27
2	Site Requirements and Specifications	33
	Site Requirements	34
	Physical Specifications	37
	Performance Specifications	41
3	Using the Pump	49
	Magnets	50
	Turn on/off	51
	Status Indicators	52
	Best Practices	53
	Leak and Waste Handling	56
	Hints for Successful Use of the Pump	58
	Setting up the Pump with the G4208A Instant Pilot	59
	Setting up the Pump with the Instrument Control Interface	60
	Solvent Information	69
	Algae Growth in HPLC Systems	79
	Prevent Blocking of Solvent Filters	80
	Normal Phase Applications	81
4	Optimizing Performance	83
	Using the Degasser	84
	Operational Hints for the Multi Channel Gradient Valve (MCGV)	85
	When to use the Seal Wash Function	86
	Choosing the Right Pump Seals	87
	Optimize the Compressibility Compensation Setting	88

5	Troubleshooting and Diagnostics	91
	User Interfaces	92
	Agilent Lab Advisor Software	93
6	Error Information	95
	What Are Error Messages	97
	General Error Messages	98
	Module Error Messages	105
7	Test Functions and Calibration	119
	Introduction	120
	System Pressure Test	121
	Leak Rate Test	126
8	Maintenance	133
	Introduction to Maintenance and Repair	134
	Warnings and Cautions	135
	Overview of Maintenance and Repair	136
	Cleaning the Module	137
	Remove and Install Doors	138
	Checking and Replacing the Solvent Filter	139
	Exchange the Passive Inlet Valve	140
	Exchange the Outlet Valve	142
	Exchange the Purge Valve Frit or the Purge Valve	144
	Replace the O-Ring on the Purge Valve	148
	Remove the Pump Head Assembly	149
	Maintenance of a Pump Head Without Seal Wash Option	151
	Maintenance of a Pump Head with Seal Wash Option	154
	Reinstall the Pump Head Assembly	158
	Seal Wear-in Procedure	160
	Exchange the Multi-Channel Gradient Valve (MCGV)	161
	Exchange the Active Inlet Valve (AIV) or its Cartridge	164
	Exchange the Seal Wash Cartridge	166
	Replace Leak Handling System Parts	167
	Replacing the Module Firmware	168

9	Parts for Maintenance	169
	Accessory Kits	170
	Pump Head Assembly Without Seal Wash	172
	Pump Head Assembly with Seal Wash	174
	Outlet Valve	176
	Purge Valve Assembly	177
	Active Inlet Valve Assembly	178
	1260 Infinity II Max Uptime Kit	179
	1260 Infinity II Low Dispersion Kit MCT	180
	HPLC System Tool Kit	181
	Solvent Cabinet	182
	Bottle Head Assembly	183
	Hydraulic Path of the Quaternary Pump	184
	Hydraulic Path of the Isocratic Pump	186
	Leak Parts	188
10	Identifying Cables	189
	Cable Overview	190
	Analog Cables	192
	Remote Cables	194
	CAN Cable	198
	Agilent Module to PC	199
	Agilent 1200 Module to Printer	200
11	Hardware Information	201
	Firmware Description	202
	Electrical Connections	205
	Interfaces	207
	Setting the 6-bit Configuration Switch	214
	Instrument Layout	218
	Early Maintenance Feedback	219
12	LAN Configuration	221
	What You Have to Do First	222
	TCP/IP parameter configuration	223
	Configuration Switches	224
	Initialization Mode Selection	225
	Dynamic Host Configuration Protocol (DHCP)	227
	Manual Configuration	230

Contents

13 Appendix 235

General Safety Information 236

Waste Electrical and Electronic Equipment Directive 242

Radio Interference 243

Sound Emission 244

Agilent Technologies on Internet 245



1 Introduction

Introduction to the Pump	10
G7110B Isocratic Pump	11
Product Description	11
Features	12
G7111A Quaternary Pump VL	13
Product Description	13
Features	14
G7111B Quaternary Pump	15
Product Description	15
Features	16
G5654A Bio-inert Pump	17
Product Description	17
Features	18
Overview of the Hydraulic Path	19
Hydraulic Path	20
How Does the Pump Work?	22
How Does Compressibility Compensation Work?	25
How Does Variable Stroke Volume Work?	26
Leak and Waste Handling	27
Waste Concept	31

This chapter gives an introduction to the module, instrument overview and internal connectors.



Introduction to the Pump

The Low Pressure Mixing Pumps comprise an optional solvent cabinet, a vacuum degasser (optional for the isocratic pump), and a four-channel gradient valve for quaternary pumps, or an optional 3-solvent selection valve for isocratic pumps. The four-channel gradient pump comprises a high-speed proportioning valve and a pump assembly. It provides gradient generation by low pressure mixing. A solvent cabinet provides enough space for eight one-liter bottles. The Active Seal Wash (ASW) and Active Inlet Valve (AIV) options are available for quaternary pumps when concentrated buffer solutions are used. The Bio-inert pump is optimized for these conditions, thus is always equipped with ASW and AIV..

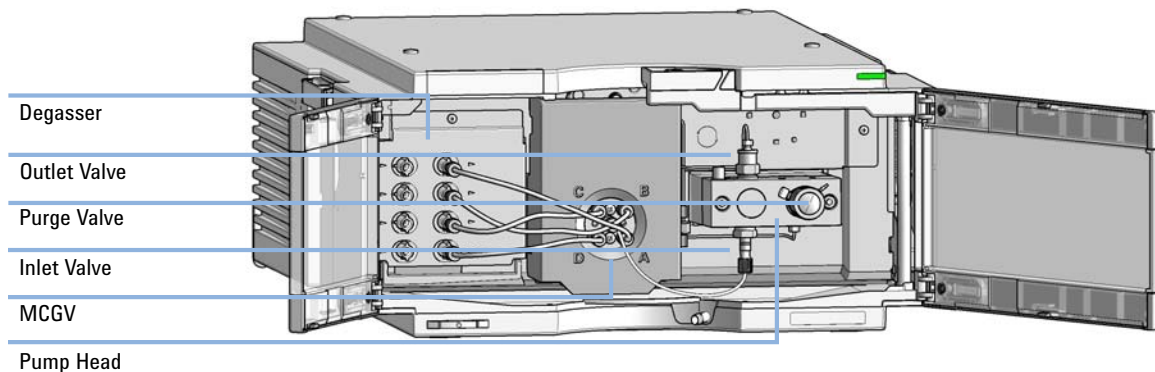

Figure 1 Overview of the pump

G7110B Isocratic Pump

Product Description

The Agilent 1260 Infinity II Isocratic Pump is ideal for demanding QA/QC tasks and routine applications. It maintains virtually pulse-free and stable solvent flows. The dual floating, precise servo-controlled pistons in the delivery mechanism adjust the stroke volume according to your chosen flow rate.

The pump can deliver a broad range of pressures up to a maximum 600 bar, giving you the flexibility to use small particle size columns, longer columns or alternative higher viscosity solvents.

The Agilent 1260 Infinity II Isocratic Pump is the ideal pump for GPC/SEC applications where run-to-run and day-to-day precision in retention times is crucial.

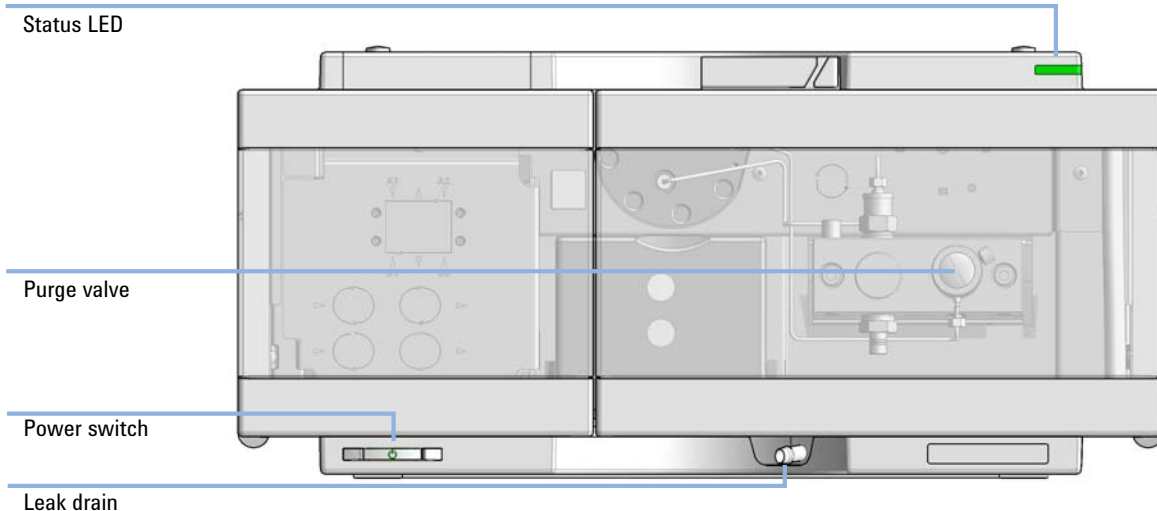

Figure 2 Overview of the pump

Features

- *Higher resolution and increased throughput* with the new standard 600 bar pressure for modern LC columns.
- *Low operating and maintenance costs* - due to excellent instrument uptime.
- *Future proof* - your investment is protected since you can upgrade to a quaternary pump if required.
- *Versatile wide flow range* – from 0.2 mL/min to 10 mL/min for analytical and semi-preparative separations and purifications.
- *Fast and easy maintenance* - front access to all maintenance parts means you can change components quickly without having to disassemble the instrument.
- *Longevity and low operating costs* - robust materials (stainless steel, titanium, gold, ruby, sapphire, ceramics, PEEK and PTFE) withstand the most demanding applications and keep your pump functioning for years. Our optional seal wash for high-salt mobile phases keeps maintenance to a minimum and reduces operating costs.

G7111A Quaternary Pump VL

Product Description

The Agilent 1260 Infinity II Quaternary Pump VL has an extended power range, delivering pressures up to 400 bar. At these high pressures you can use smaller particle size columns and get higher resolution and faster separations. It maintains virtually pulse-free, well mixed and stable solvent flows. Its dual floating, precise servo-controlled pistons adjust the stroke volume according to your chosen flow rate.

Offering access to up to four solvents, the Agilent 1260 Infinity II Quaternary Pump VL provides the greatest flexibility in automated solvent blending and is recommended for a wide range of research and routine applications (especially in the food, environmental and pharmaceutical sectors) as well as for method development.

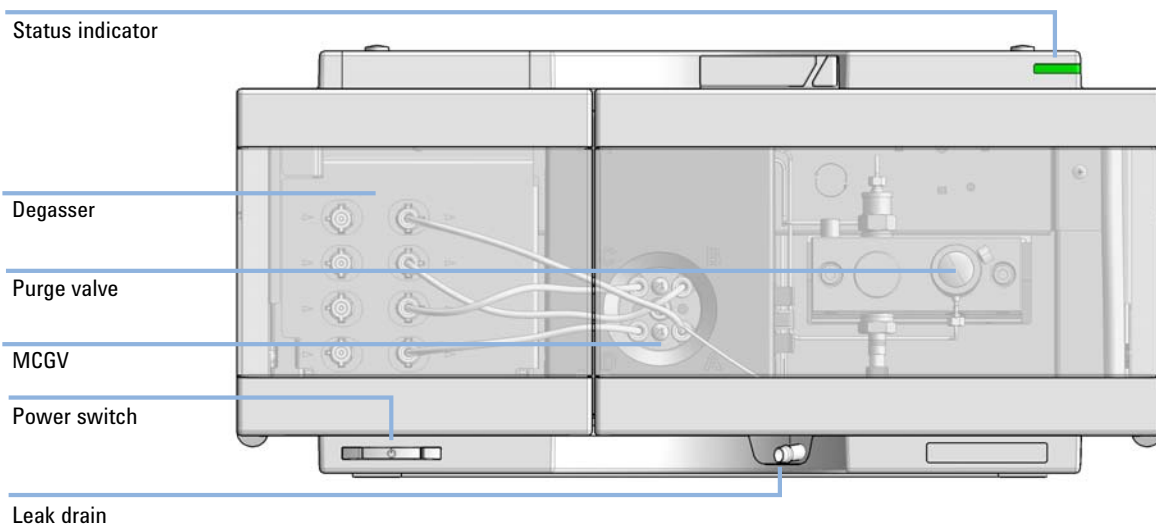

Figure 3 Overview of the pump

Features

- *Higher resolution, faster separations* - the maximum pressure of 400 bar allows you to use smaller particle size columns, longer columns and/or higher viscous solvents as an alternative to acetonitrile.
- *Analytical and semi-preparative purifications* - the wide flow range (up to 10 mL/min) perfectly supports standard and semi-preparative applications. The perfect choice for 4.6 mm and 3.0 mm id columns.
- *Quicker experiments* - the pump offers convenient access to up to four solvents for isocratic or gradient analysis which can really speed up method development, preparation of mobile phases and system flushing.
- *Easy, fast and secure transfer of methods* from HPLC to sub-2-micron columns.
- *Integrated degasser*
- *Longevity and low operating costs* - robust materials (stainless steel, titanium, gold, ruby, sapphire, ceramics, PEEK and PTFE) withstand the most demanding applications and keep your pump functioning for years. Our optional seal wash for high-salt mobile phases keeps maintenance to a minimum and reduces operating costs.

G7111B Quaternary Pump

Product Description

The Agilent 1260 Infinity II Quaternary Pump has an extended power range, delivering pressures up to 600 bar. At these high pressures you can use smaller particle size columns and get higher resolution and faster separations. It maintains virtually pulse-free, well mixed and stable solvent flows. Its dual floating, precise servo-controlled pistons adjust the stroke volume according to your chosen flow rate.

Offering access to up to four solvents, the Agilent 1260 Infinity II Quaternary Pump provides the greatest flexibility in automated solvent blending and is recommended for a wide range of research and routine applications (especially in the food, environmental and pharmaceutical sectors) as well as for method development.

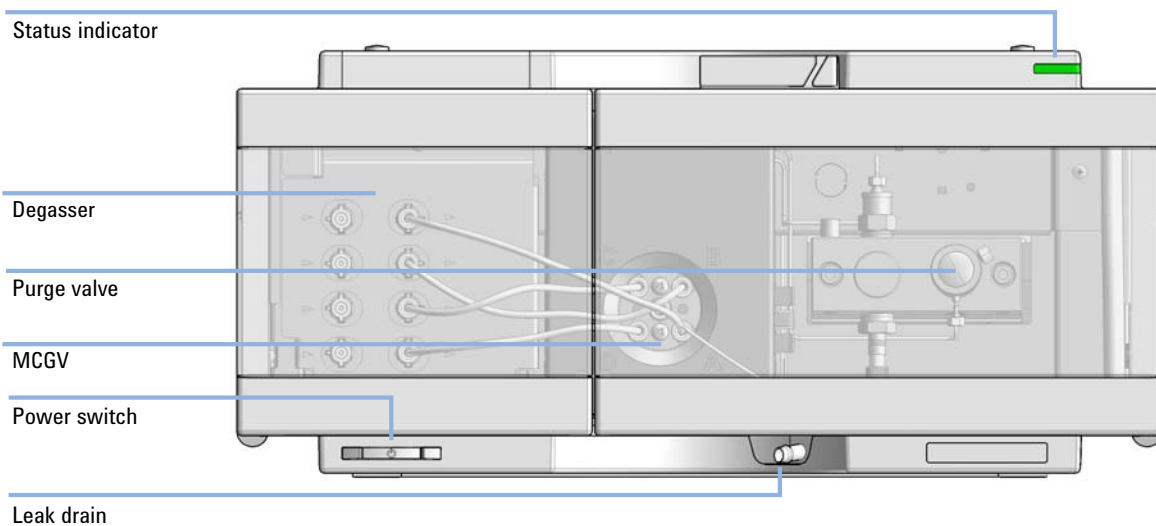

Figure 4 Overview of the pump

Features

- *Higher resolution, faster separations* - the maximum pressure of 600 bar allows you to use smaller particle size columns, longer columns and/or higher viscous solvents as an alternative to acetonitrile.
- *Analytical and semi-preparative purifications* - the wide flow range (up to 10 mL/min) perfectly supports standard and semi-preparative applications. The perfect choice for 4.6 mm and 3.0 mm id columns.
- *Quicker experiments* - the pump offers convenient access to up to four solvents for isocratic or gradient analysis which can really speed up method development, preparation of mobile phases and system flushing.
- *Easy, fast and secure transfer of methods* from HPLC to sub-2-micron columns.
- *Integrated degasser*
- *Longevity and low operating costs* - robust materials (stainless steel, titanium, gold, ruby, sapphire, ceramics, PEEK and PTFE) withstand the most demanding applications and keep your pump functioning for years. Our optional seal wash for high-salt mobile phases keeps maintenance to a minimum and reduces operating costs.

G5654A Bio-inert Pump

Product Description

The Agilent 1260 Infinity II Bio-inert Pump is the pump of choice for all your biological and extreme pH applications. The titanium-based pump offers highest corrosion resistance against high salt concentration (2 M) and offers a handling of a wide pH range (1 – 13, short term 14). It features a pressure range of up to 600 bar and a flow rate up to 10 mL/min (at 200 bar) allowing the use of almost any column – conventional, sub-2 μm -particle or superficially porous columns.

Together with the Agilent Bio-HPLC column portfolio for SEC and IEX, highest resolution per time is achieved for protein and NBE characterization. The Agilent Buffer Advisor software allows fast pH scouting and easy buffer/solvent preparation in ion exchange chromatography.

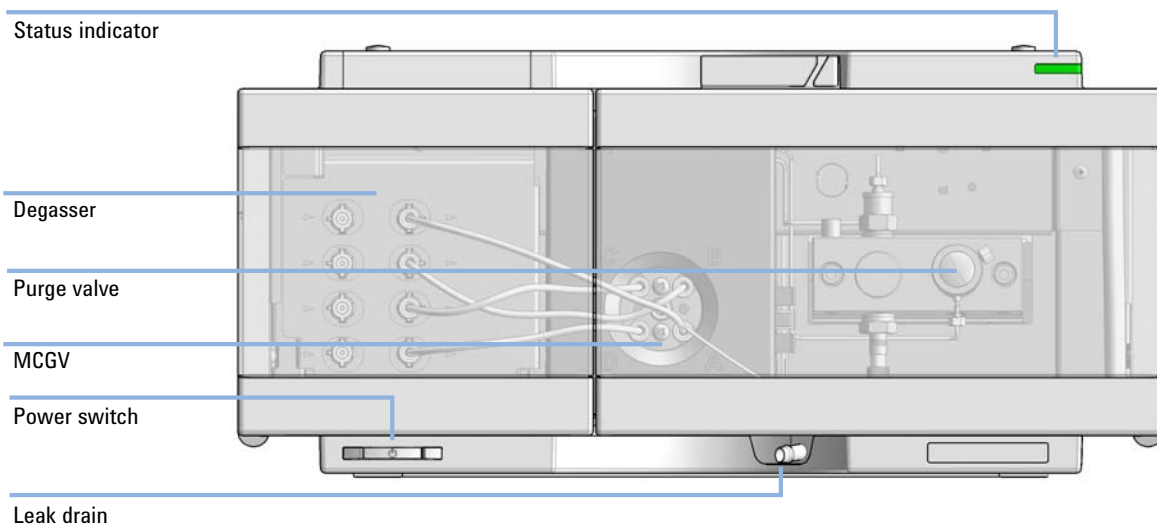

Figure 5 Overview of the pump

Features

- *Titanium pump* - for highest corrosion resistance against high salt concentrations and harsh cleaning procedures
- *Steel and iron-free wetted parts in solvent delivery unit* - ensure the integrity of bio-molecules and minimize unwanted surface interactions while increasing column life-time
- *High salt tolerance (2 M) and wide pH range (1 - 13, short term 14)* - for increased flexibility
- *Flow rates up to 10 mL/min* - enable power ranges from lowest pressure for traditional bio-purification columns up to high pressure STM analytical bio-columns
- Active seal wash and quaternary solvent blending included
- Comes with *Agilent Buffer Advisor software* - for faster pH scouting and easy buffer/solvent preparation in ion exchange chromatography

Overview of the Hydraulic Path

The Low Pressure Mixing Pumps are based on a two-channel, dual-piston in-series design which comprises all essential functions that a solvent delivery system has to fulfill. Metering of solvent and delivery to the high-pressure side are performed by one pump assembly which can generate pressure up to 600 bar.

In the quaternary pumps, degassing of the solvents is done in a built-in vacuum degasser. Solvent compositions are generated on the low-pressure side by a multi-channel gradient valve (MCGV), which is a high-speed proportioning valve.

The pump assembly includes a pump head with an inlet valve and an outlet valve. A damping unit is connected between the two piston chambers. A purge valve including a PTFE frit is fitted at the pump outlet for convenient priming of the pump head.

Hydraulic Path

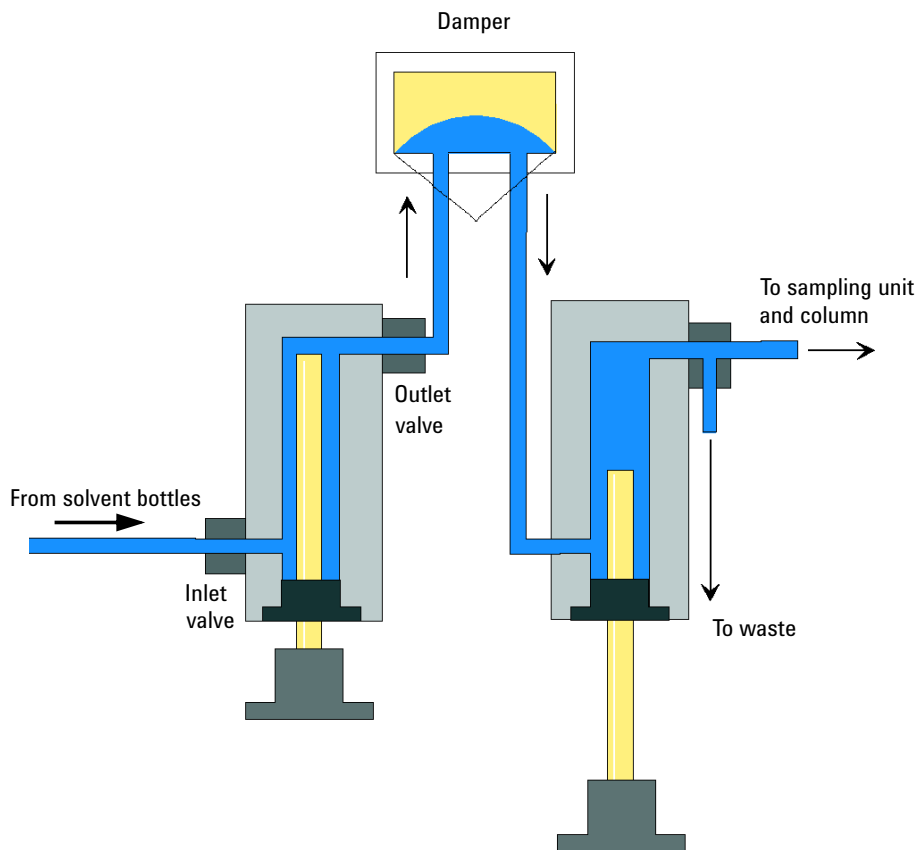

Figure 6 Hydraulic Path of the Isocratic Pump

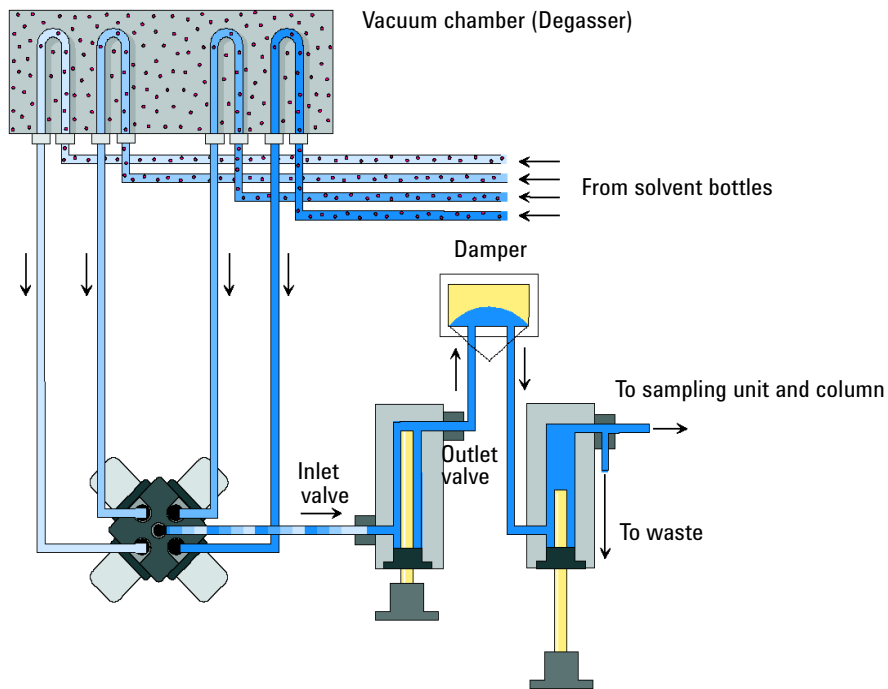

Figure 7 Hydraulic Path of the Quaternary Pump and Bio-inert Pump

How Does the Pump Work?

In the quaternary pump, the liquid runs from the solvent reservoir through the degasser to the MCGV and from there to the inlet valve.

For the isocratic pump, the solvent bottle is directly connected to the inlet valve.

The pump assembly comprises two substantially identical piston/chamber units. Both piston/chamber units comprise a ball-screw drive and a pump head with one sapphire piston for reciprocating movement in it.

A servo-controlled variable reluctance motor drives the two ball screw drives in opposite directions. The gears for the ball-screw drives have different circumferences (ratio 2:1) allowing the first piston to move at twice the speed of the second piston. The solvent enters the pump head close to the bottom limit and leaves it at its top. The outer diameter of the piston is smaller than the inner diameter of the pump head chamber allowing the solvent to fill the gap inbetween. The first piston has a stroke volume in the range of 20 – 100 μL depending on the flow rate. The microprocessor controls all flow rates in a range of 1 $\mu\text{L}/\text{min}$ – 10 mL/min . The inlet of the first pumping unit is connected to the inlet valve.

The outlet of the first piston/chamber unit is connected through the outlet valve and the damping unit to the inlet of the second piston/chamber unit. The outlet of the purge valve assembly is then connected to the following chromatographic system.

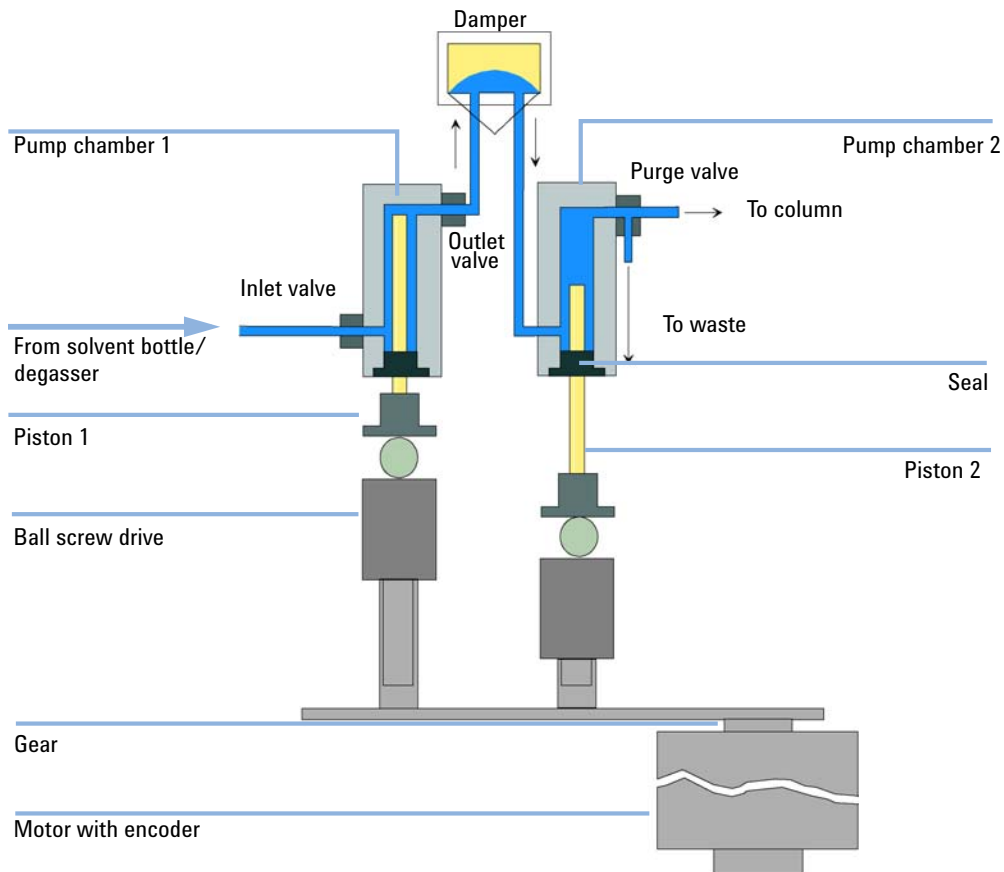

Figure 8 Principle of the Pump

When turned on, the pump runs through an initialization procedure to determine the upper dead position of the first piston. The first piston moves slowly upwards into the mechanical stop of the pump chamber and from there it moves back for a defined distance. The controller stores this piston position in memory. After this initialization the pump starts operation with the set parameters. The inlet valve opens and the down-moving piston draws solvent into the first pump chamber. At the same time the second piston moves upwards delivering to the system. After a controller-defined stroke length that depends on the flow rate the drive motor is stopped and the inlet valve closes. The motor direction is reversed and moves the first piston up until it reaches the stored upper limit and at the same time the second piston moves downwards. Then the sequence starts again moving the pistons up and down between the two limits. During the up movement of the first piston the solvent in the pump chamber is pressed through the outlet valve into the second pump chamber. The second piston draws in half of the volume displaced by the first piston and the remaining half volume is directly delivered to the system. During the drawing stroke of the first piston, the second piston delivers the drawn volume to the system.

Quaternary pumps: For solvent compositions from the solvent bottles A, B, C, D the controller divides the length of the intake stroke in certain fractions in which the gradient valve connects the specified solvent channel to the pump input.

For specifications, see:

- isocratic pump: [“Performance Specifications Agilent 1260 Infinity II Isocratic Pump \(G7110B\)”](#) on page 41
- quaternary pumps:
 - [“Performance Specifications Agilent 1260 Infinity II Quaternary Pump \(G7111B\)”](#) on page 45
 - [“Performance Specifications Agilent 1260 Infinity II Quaternary Pump VL \(G7111A\)”](#) on page 43
- Bio-inert pump: [“Performance Specifications Agilent 1260 Infinity II Bio-inert Pump \(G5654A\)”](#) on page 47

How Does Compressibility Compensation Work?

The compressibility of the solvents in use will affect retention-time stability when the back pressure in the system changes (for example, ageing of column). In order to minimize this effect, the pump provides a compressibility compensation feature which optimizes the flow stability according to the solvent type. The compressibility compensation is set to a default value and can be changed through the user interface.

Without a compressibility compensation the following will happen during a stroke of the first piston. The pressure in the piston chamber increases and the volume in the chamber will be compressed depending on back pressure and solvent type. The volume displaced into the system will be reduced by the compressed volume.

With a compressibility value set the processor calculates a compensation volume, that depends on the back pressure of the system and the selected compressibility. This compensation volume will be added to the normal stroke volume and compensates the previously described *loss* of volume during the delivery stroke of the first piston.

How Does Variable Stroke Volume Work?

Due to the compression of the pump-chamber volume each piston stroke of the pump will generate a small pressure pulsation, influencing the flow stability of the pump. The amplitude of the pressure pulsation depends mainly on the stroke volume and the compressibility compensation for the solvent in use. Small stroke volumes generate pressure pulsations of smaller amplitude than higher stroke volumes at the same flow rate. In addition, the frequency of the pressure pulsations is higher. This decreases the influence of flow pulsations on quantitative results.

In gradient mode, smaller stroke volumes result in a lower flow ripple and will improve composition ripple.

The module uses a processor-controlled spindle system for driving its pistons. The normal stroke volume is optimized for the selected flow rate. Small flow rates use a small stroke volume while higher flow rates use a higher stroke volume.

By default, the stroke volume for the pump is set to AUTO mode. This means that the stroke is optimized for the flow rate in use. A change to larger stroke volumes is possible but not recommended.

Leak and Waste Handling

The Agilent InfinityLab LC Series has been designed for safe leak and waste handling. It is important that all security concepts are understood and instructions are carefully followed.

The solvent cabinet is designed to store a maximum volume of 8 L solvent. The maximum volume for an individual bottle stored in the solvent cabinet should not exceed 2 L. For details, see the usage guideline for the Agilent 1200 Infinity Series Solvent Cabinets (a printed copy of the guideline has been shipped with the solvent cabinet, electronic copies are available on the Internet).

All leak plane outlets are situated in a consistent position so that all Infinity and Infinity II modules can be stacked on top of each other. Waste tubes are guided through a channel on the right hand side of the instrument, keeping the front access clear from tubes.

The leak plane provides leak management by catching all internal liquid leaks, guiding them to the leak sensor for leak detection, and passing them on to the next module below, if the leak sensor fails. The leak sensor in the leak plane stops the running system as soon as the leak detection level is reached.

Solvent and condensate is guided through the waste channel into the waste container:

- from the detector's flow cell outlet
- from the Multisampler needle wash port
- from the Sample Cooler (condensate)
- from the Seal Wash Sensor
- from the pump's Purge Valve or Multipurpose Valve

1 Introduction
Leak and Waste Handling

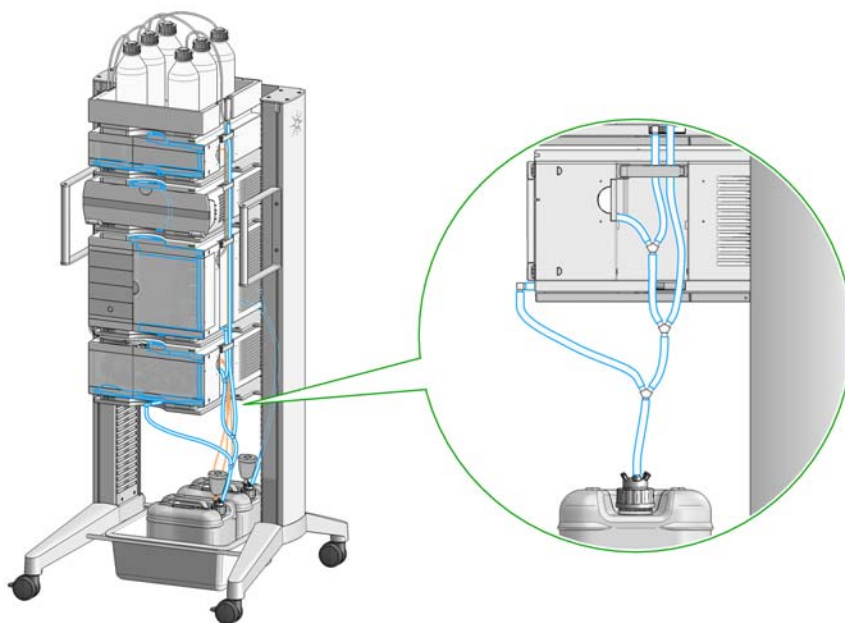

Figure 9 Infinity II Leak Waste Concept (flexible rack installation)

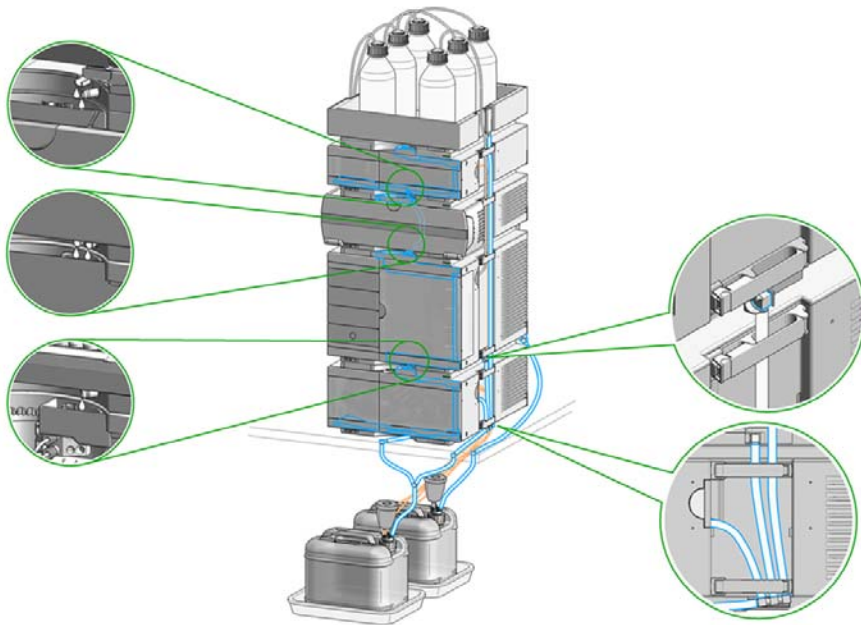

Figure 10 Infinity II Single Stack Leak Waste Concept (bench installation)

1 Introduction

Leak and Waste Handling

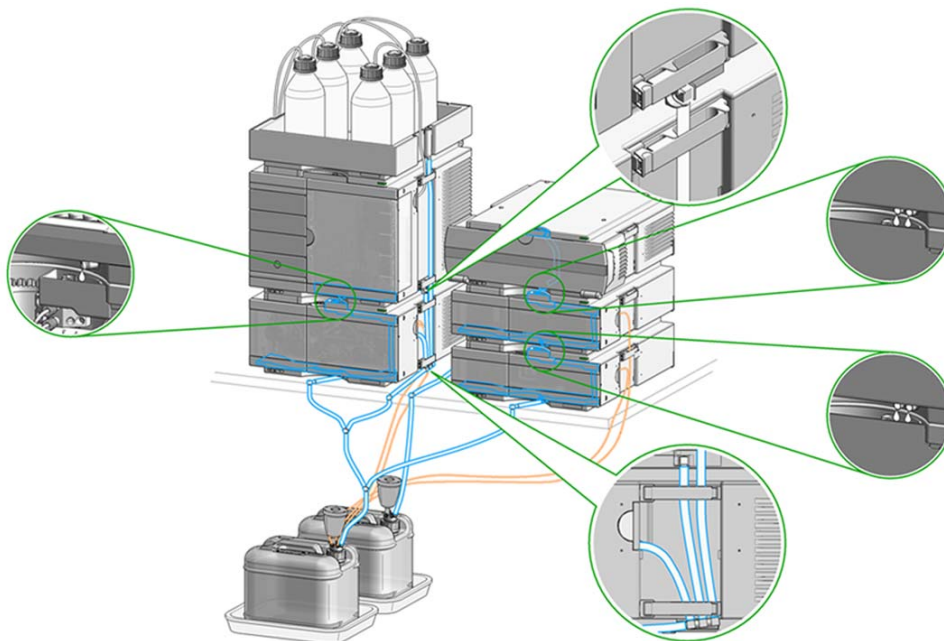

Figure 11 Infinity II Two Stack Leak Waste Concept (bench installation)

The waste tube connected to the leak pan outlet on each of the bottom instruments guides the solvent to a suitable waste container.

Waste Concept

- 1 Agilent recommends using the 6 L waste can with 1 Stay Safe cap GL45 with 4 ports (5043-1221) for optimal and safe waste disposal. If you decide to use your own waste solution, make sure that the tubes don't immerse in the liquid.



1 Introduction
Leak and Waste Handling



2 Site Requirements and Specifications

Site Requirements 34

Physical Specifications 37

Physical Specifications Agilent 1260 Infinity II Isocratic Pump
(G7110B) 37

Physical Specifications Agilent 1260 Infinity II Quaternary Pump VL
(G7111A) 38

Physical Specifications Agilent 1260 Infinity II Quaternary Pump
(G7111B) 39

Physical Specifications Agilent 1260 Infinity II Bio-inert Pump
(G5654A) 40

Performance Specifications 41

This chapter provides information on environmental requirements, physical and performance specifications.



Site Requirements

A suitable environment is important to ensure optimal performance of the instrument.

Power Considerations

The module power supply has wide ranging capability. It accepts any line voltage in the range described in [Table 1](#) on page 37. Consequently there is no voltage selector in the rear of the module. There are also no externally accessible fuses, because automatic electronic fuses are implemented in the power supply.

WARNING

Hazard of electrical shock or damage of your instrumentation can result, if the devices are connected to a line voltage higher than specified.

→ Connect your instrument to the specified line voltage only.

WARNING

The module is partially energized when switched off, as long as the power cord is plugged in.

Repair work at the module can lead to personal injuries, e.g. electrical shock, when the cover is opened and the module is connected to power.

→ Always unplug the power cable before opening the cover.

→ Do not connect the power cable to the instrument while the covers are removed.

WARNING

Inaccessible power plug.

In case of emergency it must be possible to disconnect the instrument from the power line at any time.

→ Make sure the power connector of the instrument can be easily reached and unplugged.

→ Provide sufficient space behind the power socket of the instrument to unplug the cable.

Power Cords

Country-specific power cords are available for the module. The female end of all power cords is identical. It plugs into the power-input socket at the rear. The male end of each power cord is different and designed to match the wall socket of a particular country or region.

Agilent makes sure that your instrument is shipped with the power cord that is suitable for your particular country or region.

WARNING

Absence of ground connection

The absence of ground connection can lead to electric shock or short circuit.

- Never operate your instrumentation from a power outlet that has no ground connection.
-

WARNING

Unintended use of supplied power cords

Using power cords for unintended purposes can lead to personal injury or damage of electronic equipment.

- Never use a power cord other than the one that Agilent shipped with this instrument.
 - Never use the power cords that Agilent Technologies supplies with this instrument for any other equipment.
 - Never use cables other than the ones supplied by Agilent Technologies to ensure proper functionality and compliance with safety or EMC regulations.
-

WARNING

Power cords

Solvents may damage electrical cables.

- Prevent electrical cables from getting in contact with solvents.
 - Exchange electrical cables after contact with solvents.
-

Bench Space

The module dimensions and weight (see [Table 1](#) on page 37) allow you to place the module on almost any desk or laboratory bench. It needs an additional 2.5 cm (1.0 inches) of space on either side and approximately 8 cm (3.1 inches) in the rear for air circulation and electric connections.

If the bench shall carry a complete HPLC system, make sure that the bench is designed to bear the weight of all modules.

The module should be operated in a horizontal position.

NOTE

Agilent recommends that you install the HPLC instrument in the A-Line Flex Bench rack. This option helps to save bench space as all modules can be placed into one single stack. It also allows to easily relocate the instrument to another Lab.

Condensation

CAUTION

Condensation within the module

Condensation can damage the system electronics.

- Do not store, ship or use your module under conditions where temperature fluctuations could cause condensation within the module.
 - If your module was shipped in cold weather, leave it in its box and allow it to warm slowly to room temperature to avoid condensation.
-

Physical Specifications

Physical Specifications Agilent 1260 Infinity II Isocratic Pump (G7110B)

Table 1 Physical Specifications

Type	Specification	Comments
Weight	14.0 kg (31 lbs)	
Dimensions (height × width × depth)	180 × 396 × 436 mm (7.1 × 15.6 × 17.2 inches)	
Line voltage	100 – 240 V~, ± 10 %	Wide-ranging capability
Line frequency	50 or 60 Hz, ± 5 %	
Power consumption	80 VA, 65 W	
Ambient operating temperature	4–55 °C (39–131 °F)	
Ambient non-operating temperature	-40 – 70 °C (-40 – 158 °F)	
Humidity	< 95 % r.h. at 40 °C (104 °F)	Non-condensing
Operating altitude	Up to 3000 m (9842 ft)	
Non-operating altitude	Up to 4600 m (15092 ft)	For storing the module
Safety standards: IEC, EN, CSA, UL	Installation category II, Pollution degree 2	For indoor use only.
ISM Classification	ISM Group 1 Class B	According to CISPR 11

Physical Specifications Agilent 1260 Infinity II Quaternary Pump VL (G7111A)

Table 2 Physical Specifications

Type	Specification	Comments
Weight	14.7 kg (32 lbs)	
Dimensions (height × width × depth)	180 × 396 × 436 mm (7.1 × 15.6 × 17.2 inches)	
Line voltage	100 – 240 V~, ± 10 %	Wide-ranging capability
Line frequency	50 or 60 Hz, ± 5 %	
Power consumption	80 VA, 65 W	
Ambient operating temperature	4–55 °C (39–131 °F)	
Ambient non-operating temperature	-40 – 70 °C (-40 – 158 °F)	
Humidity	< 95 % r.h. at 40 °C (104 °F)	Non-condensing
Operating altitude	Up to 3000 m (9842 ft)	
Non-operating altitude	Up to 4600 m (15092 ft)	For storing the module
Safety standards: IEC, EN, CSA, UL	Installation category II, Pollution degree 2	For indoor use only.
ISM Classification	ISM Group 1 Class B	According to CISPR 11

Physical Specifications Agilent 1260 Infinity II Quaternary Pump (G7111B)

Table 3 Physical Specifications

Type	Specification	Comments
Weight	14.7 kg (32 lbs)	
Dimensions (height × width × depth)	180 × 396 × 436 mm (7.1 × 15.6 × 17.2 inches)	
Line voltage	100 – 240 V~, ± 10 %	Wide-ranging capability
Line frequency	50 or 60 Hz, ± 5 %	
Power consumption	80 VA, 65 W	
Ambient operating temperature	4–55 °C (39–131 °F)	
Ambient non-operating temperature	-40 – 70 °C (-40 – 158 °F)	
Humidity	< 95 % r.h. at 40 °C (104 °F)	Non-condensing
Operating altitude	Up to 3000 m (9842 ft)	
Non-operating altitude	Up to 4600 m (15092 ft)	For storing the module
Safety standards: IEC, EN, CSA, UL	Installation category II, Pollution degree 2	For indoor use only.
ISM Classification	ISM Group 1 Class B	According to CISPR 11

Physical Specifications Agilent 1260 Infinity II Bio-inert Pump (G5654A)

Table 4 Physical Specifications

Type	Specification	Comments
Weight	14.7 kg (32 lbs)	
Dimensions (height × width × depth)	180 × 396 × 436 mm (7.1 × 15.6 × 17.2 inches)	
Line voltage	100 – 240 V~, ± 10 %	Wide-ranging capability
Line frequency	50 or 60 Hz, ± 5 %	
Power consumption	80 VA, 65 W	
Ambient operating temperature	4–55 °C (39–131 °F)	
Ambient non-operating temperature	-40 – 70 °C (-40 – 158 °F)	
Humidity	< 95 % r.h. at 40 °C (104 °F)	Non-condensing
Operating altitude	Up to 3000 m (9842 ft)	
Non-operating altitude	Up to 4600 m (15092 ft)	For storing the module
Safety standards: IEC, EN, CSA, UL	Installation category II, Pollution degree 2	For indoor use only.
ISM Classification	ISM Group 1 Class B	According to CISPR 11

Performance Specifications

Performance Specifications Agilent 1260 Infinity II Isocratic Pump (G7110B)

Table 5 Performance Specifications Agilent 1260 Infinity II Isocratic Pump (G7110B)

Type	Specification
Hydraulic system	Dual piston in series pump with servo-controlled variable stroke drive, power transmission by gears and ball screws, floating pistons
Settable flow range	Set points 0.001 – 10 mL/min, in 0.001 mL/min increments
Recommended flow range	0.2 – 10.0 mL/min
Flow precision	≤0.07 % RSD, or ≤0.02 min SD whatever is greater, based on retention time at constant room temperature
Flow accuracy	± 1 % or 10 µL/min whatever is greater, pumping degassed H ₂ O at 10 MPa (100 bar)
Pressure operating range	Operating range up to 60 MPa (600 bar, 8700 psi) up to 5 mL/min Operating range up to 20 MPa (200 bar, 2950 psi) up to 10 mL/min
Pressure pulsation	< 2 % amplitude (typically < 1.3 %), or < 0.3 MPa (3 bar, 44 psi), whatever is greater, at 1 mL/min isopropanol, at all pressures > 1 MPa (10 bar, 145 psi)
Compressibility compensation	User-selectable, based on mobile phase compressibility
Control	Agilent control software (e.g. ChemStation, EZChrom, OL, MassHunter)
Local control	Agilent Instant Pilot
Communications	Controller-area network (CAN), RS-232C, APG Remote: ready, start, stop and shut-down signals, LAN optional
Safety and maintenance	Extensive diagnostics, error detection and display through Agilent LabAdvisor, leak detection, safe leak handling, leak output signal for shutdown of the pumping system. Low voltage in major maintenance areas.

2 Site Requirements and Specifications

Performance Specifications

Table 5 Performance Specifications Agilent 1260 Infinity II Isocratic Pump (G7110B)

GLP features	Early maintenance feedback (EMF) for continuous tracking of instrument usage in terms of seal wear and volume of pumped mobile phase with pre-defined and user settable limits and feedback messages. Electronic records of maintenance and errors
Housing	All materials are recyclable

NOTE

For use with flow rates below 500 $\mu\text{L}/\text{min}$ a vacuum degasser is required.

Performance Specifications Agilent 1260 Infinity II Quaternary Pump VL (G7111A)

Table 6 Performance Specifications Agilent 1260 Infinity II Quaternary Pump VL (G7111A)

Type	Specification
Hydraulic system	Dual piston in series pump with servo-controlled variable stroke drive, power transmission by gears and ball screws, floating pistons
Settable flow range	Set points 0.001 – 10 mL/min, in 0.001 mL/min increments
Recommended flow range	0.2 – 10.0 mL/min
Flow precision	≤0.07 % RSD, or ≤0.02 min SD whatever is greater, based on retention time at constant room temperature
Flow accuracy	± 1 % or 10 µL/min whatever is greater, pumping degassed H ₂ O at 10 MPa (100 bar)
Pressure operating range	Operating range up to 40 MPa (400 bar, 5880 psi) up to 5 mL/min Operating range up to 20 MPa (200 bar, 2950 psi) up to 10 mL/min
Pressure pulsation	< 2 % amplitude (typically < 1.0 %), or < 0.3 MPa (3 bar, 44 psi), whatever is greater, at 1 mL/min isopropanol, at all pressures > 1 MPa (10 bar, 145 psi)
Compressibility compensation	User-selectable, based on mobile phase compressibility
Recommended pH range	1.0 – 12.5, solvents with pH < 2.3 should not contain acids which attack stainless steel
Gradient formation	Low pressure quaternary mixing/gradient capability using proprietary high-speed proportioning valve
Delay volume	800 – 1100 µL, dependent on back pressure; measured with water at 1 mL/min (water/caffeine tracer)
Settable composition range	0 – 100 % in 0.1 % increments
Composition precision	< 0.2 % RSD or < 0.04 min SD, whatever is greater, at 1 mL/min; based on retention time at constant room temperature

2 Site Requirements and Specifications

Performance Specifications

Table 6 Performance Specifications Agilent 1260 Infinity II Quaternary Pump VL (G7111A)

Integrated degassing unit	Number of channels: 4 Internal volume per channel: 1.5 mL
Control	Agilent control software (e.g. ChemStation, EZChrom, OL, MassHunter)
Local control	Agilent Instant Pilot
Communications	Controller-area network (CAN), RS-232C, APG Remote: ready, start, stop and shut-down signals, LAN optional
Safety and maintenance	Extensive diagnostics, error detection and display through Agilent LabAdvisor, leak detection, safe leak handling, leak output signal for shutdown of the pumping system. Low voltage in major maintenance areas.
GLP features	Early maintenance feedback (EMF) for continuous tracking of instrument usage in terms of seal wear and volume of pumped mobile phase with pre-defined and user settable limits and feedback messages. Electronic records of maintenance and errors
Housing	All materials are recyclable

Performance Specifications Agilent 1260 Infinity II Quaternary Pump (G7111B)

Table 7 Performance Specifications Agilent 1260 Infinity II Quaternary Pump (G7111B)

Type	Specification
Hydraulic system	Dual piston in series pump with servo-controlled variable stroke drive, power transmission by gears and ball screws, floating pistons
Settable flow range	Set points 0.001 – 10 mL/min, in 0.001 mL/min increments
Recommended flow range	0.2 – 10.0 mL/min
Flow precision	≤0.07 % RSD, or ≤0.02 min SD whatever is greater, based on retention time at constant room temperature
Flow accuracy	± 1 % or 10 µL/min whatever is greater, pumping degassed H ₂ O at 10 MPa (100 bar)
Pressure operating range	800 – 1100 µL, dependent on back pressure; measured with water at 1 mL/min (water/caffeine tracer)
Pressure pulsation	< 2 % amplitude (typically < 1.0 %), or < 0.3 MPa (3 bar, 44 psi), whatever is greater, at 1 mL/min isopropanol, at all pressures > 1 MPa (10 bar, 145 psi)
Compressibility compensation	User-selectable, based on mobile phase compressibility
Recommended pH range	1.0 – 12.5, solvents with pH < 2.3 should not contain acids which attack stainless steel
Gradient formation	Low pressure quaternary mixing/gradient capability using proprietary high-speed proportioning valve
Delay volume	800 – 1100 µL, dependent on back pressure; measured with water at 1 mL/min (water/caffeine tracer)
Settable composition range	0 – 100 % in 0.1 % increments
Composition precision	< 0.2 % RSD or < 0.04 min SD, whatever is greater, at 1 mL/min; based on retention time at constant room temperature
Integrated degassing unit	Number of channels: 4 Internal volume per channel: 1.5 mL

2 Site Requirements and Specifications

Performance Specifications

Table 7 Performance Specifications Agilent 1260 Infinity II Quaternary Pump (G7111B)

Control	Agilent control software (e.g. ChemStation, EZChrom, OL, MassHunter)
Local control	Agilent Instant Pilot
Communications	Controller-area network (CAN), RS-232C, APG Remote: ready, start, stop and shut-down signals, LAN optional
Safety and maintenance	Extensive diagnostics, error detection and display through Agilent LabAdvisor, leak detection, safe leak handling, leak output signal for shutdown of the pumping system. Low voltage in major maintenance areas.
GLP features	Early maintenance feedback (EMF) for continuous tracking of instrument usage in terms of seal wear and volume of pumped mobile phase with pre-defined and user settable limits and feedback messages. Electronic records of maintenance and errors
Housing	All materials are recyclable

NOTE

For use with flow rates below 500 $\mu\text{L}/\text{min}$ a vacuum degasser is required.

Performance Specifications Agilent 1260 Infinity II Bio-inert Pump (G5654A)

Table 8 Performance Specifications Agilent 1260 Infinity II Bio-inert Pump (G5654A)

Type	Specification
Hydraulic system	Dual piston in series pump with proprietary servo-controlled variable stroke drive, floating pistons and active inlet valve, integrated 4-channel degassing unit
Settable flow range	0.001 – 10 mL/min, in 0.001 mL/min increments
Flow precision	< 0.07 % RSD, or <0.02 min SD whichever is greater, based on retention time at constant temperature
Flow accuracy	± 1 % or 10 µL/min whichever is greater
Pressure	Operating range up to 60 MPa (600 bar, 8700 psi) up to 5 mL/min Operating range up to 20 MPa (200 bar, 2950 psi) up to 10 mL/min
Pressure pulsation	< 2 % amplitude (typically < 1.3 %), at 1 mL/min isopropanol, at all pressures > 1 MPa (10 bar)
Compressibility compensation	User-selectable, based on mobile phase compressibility
Recommended pH range	1 – 13, short term 14 ¹
Gradient formation	Low pressure quaternary mixing/gradient capability using proprietary high-speed proportioning valve Delay volume 600 – 900 µL, dependent on back pressure.
Composition range	0 – 100 % in 0.1 % increments
Composition precision	< 0.2 % RSD, at 0.2 and 1 mL/min
Communications	Controller-area network (CAN), USB Extended Remote Interface: ready, start, stop and shut-down signals
Materials in flowpath	Titanium, Gold, Platinum-Iridium, Sapphire, PEEK, PTFE, Ruby, Ceramic, FEP, PFA
Active seal wash	Included

¹ For solvent compatibility, refer to section "Solvent information for parts of the 1260 Infinity Bio-inert LC system" in the manual

2 Site Requirements and Specifications

Performance Specifications

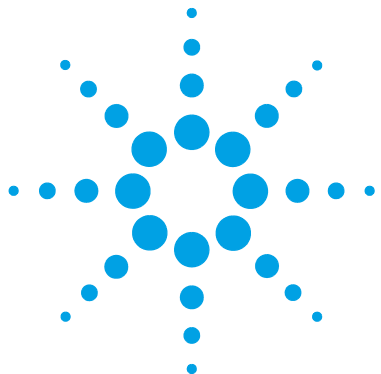

3 Using the Pump

Magnets	50
Turn on/off	51
Status Indicators	52
Best Practices	53
Daily / Weekly tasks	53
Power up / Shut-down the pump	53
Prepare the pump	54
How to deal with solvents	55
Select channels for Multi-Channel Gradient Valve (MCGV)	55
Leak and Waste Handling	56
Waste Concept	57
Hints for Successful Use of the Pump	58
Setting up the Pump with the G4208A Instant Pilot	59
Setting up the Pump with the Instrument Control Interface	60
Overview	60
Instrument Configuration	61
The Pump User Interface (Dashboard Panel)	62
Control Settings	64
Method Parameter Settings	65
Solvent Information	69
Materials in Flow Path	70
Bio-inert Materials	72
Material Information	74
Algae Growth in HPLC Systems	79
How to Prevent and-or Reduce the Algae Problem	79
Prevent Blocking of Solvent Filters	80
Normal Phase Applications	81

This chapter provides information for optimized usage of the module.



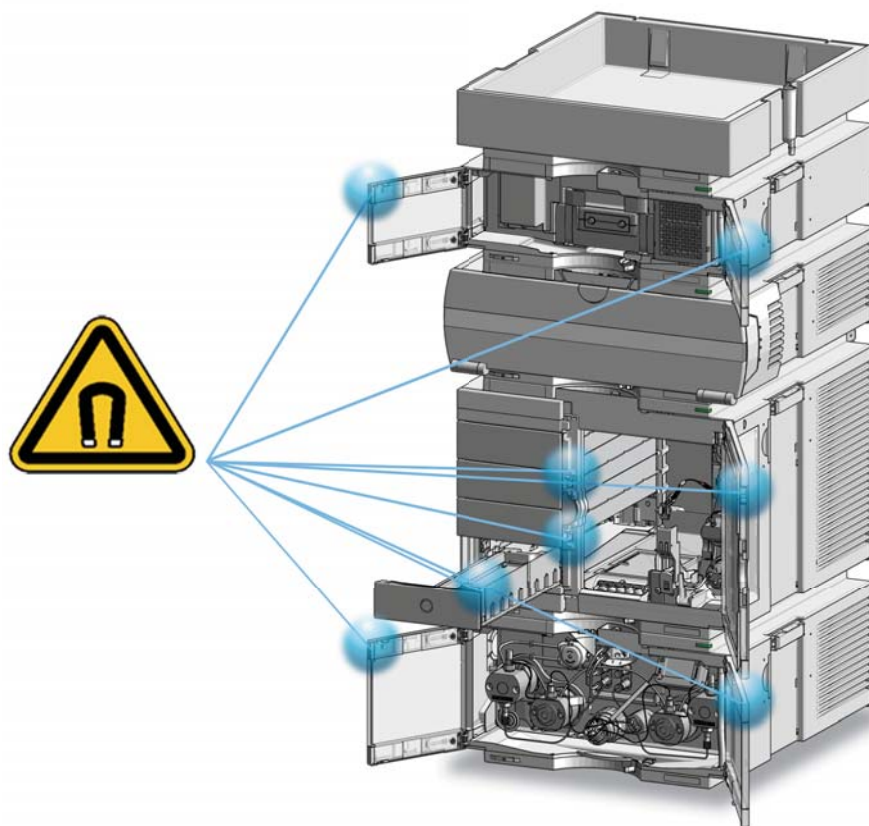

Magnets

- 1 This stack exemplarily shows the magnets' positions in the modules.

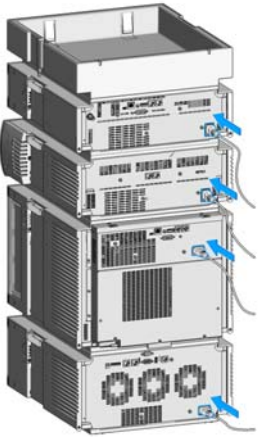

Turn on/off

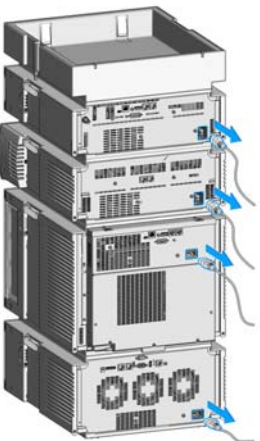
<p>1</p> 	<p>2</p>  <p>Power switch (1) On (2) Off</p>
<p>3</p> 	

Status Indicators

- 1 The module status indicator indicates one of six possible module conditions:

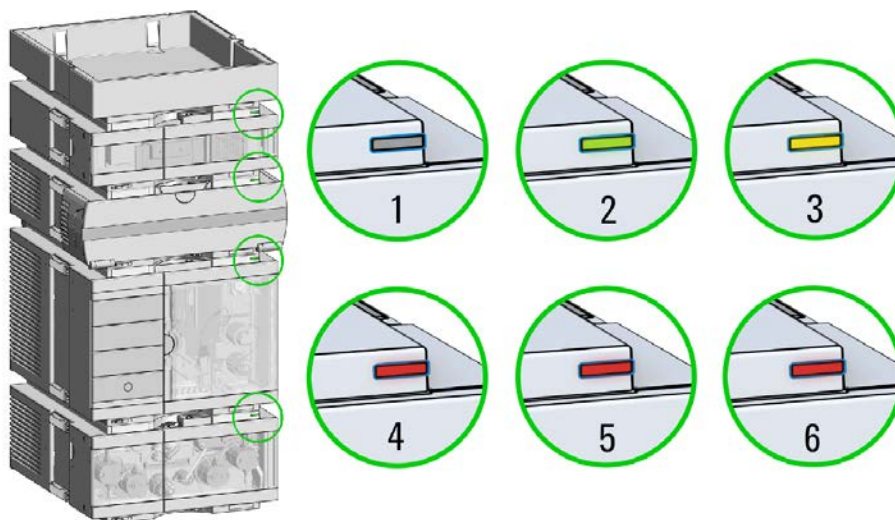

Status indicators

1. Idle
2. Run mode
3. Not-ready. Waiting for a specific pre-run condition to be reached or completed.
4. Error mode - interrupts the analysis and requires attention (for example a leak or defective internal components).
5. Resident mode (blinking) - for example during update of main firmware.
6. Bootloader mode (fast blinking). Try to re-boot the module or try a cold-start. Then try a firmware update.

Best Practices

Daily / Weekly tasks

Daily tasks

- Replace mobile phase based on water/buffer.
- Replace organic mobile phase latest every second day.
- Check seal wash solvent.

Weekly tasks

- Change seal wash solvent (10 % / 90 % isopropanol/water) and bottle.
- Flush all channels with water to remove salt deposits.
- Visually inspect solvent filters. Clean or exchange if necessary.

Power up / Shut-down the pump

Power up the pump

- Use new or different mobile phase (as required).
- Purge pump heads with 2.5 – 3 mL/min for 5 min.
- Stabilize the system by running for 10 – 20 min.

Long-term shut-down of the pump

- Flush system with water to remove buffer.
- Use recommended solvents to store the system.
- Power off the pump or system.

Prepare the pump

Purge

Use the Purge function to:

- fill the pump,
- exchange a solvent,
- remove air bubbles in tubes and pump heads.

Seal wash

The seal wash function runs continuously and is controlled by the seal wash sensor. This guarantees a maximum seal life time.

CAUTION

Contaminated seal wash solvent

- Do not recycle seal wash solvent to avoid contamination.
 - Weekly exchange seal wash solvent.
-

How to deal with solvents

- Use clean bottles only.
- Exchange water-based solvents daily.
- Select solvent volume to be used up within 1 – 2 days.
- Use only HPLC-grade solvents and water filtered through 0.2 µm filters.
- Label bottles correctly with bottle content, and filling date / expiry date.
- Use solvent inlet filters.
- Reduce risk of algae growth: use brown bottles for aqueous solvents, avoid direct sunlight.

Select channels for Multi-Channel Gradient Valve (MCGV)

- Use lower channels (A and/or D) for buffer solutions.
- Regularly flush all MCGV channels with water to remove possible salt deposits.
- Check compatibility of buffers and organic solvents to avoid precipitation.

Leak and Waste Handling

WARNING

Toxic, flammable and hazardous solvents, samples and reagents

The handling of solvents, samples and reagents can hold health and safety risks.

- When working with these substances observe appropriate safety procedures (for example by wearing goggles, safety gloves and protective clothing) as described in the material handling and safety data sheet supplied by the vendor, and follow good laboratory practice.
- Do not use solvents with an auto-ignition temperature below 200 °C (392 °F). Do not use solvents with a boiling point below 56 °C (133 °F).
- Avoid high vapor concentrations. Always keep the temperature in the sample compartment at least 25 K below the boiling point of the solvent used.
- Do not operate the instrument in an explosive atmosphere.
- Reduce the volume of substances to the minimum required for the analysis.
- Never exceed the maximum permissible volume of solvents (8 L) in the solvent cabinet. Do not use bottles that exceed the maximum permissible volume as specified in the usage guideline for solvent cabinet.
- Ground the waste container.
- Regularly check the filling level of the waste container. The residual free volume in the waste container must be large enough to collect the waste liquid.
- To achieve maximal safety, regularly check the tubing for correct installation.

NOTE

For details, see the usage guideline for the solvent cabinet. A printed copy of the guideline has been shipped with the solvent cabinet, electronic copies are available in the Agilent Information Center or via the Internet.

For details on correct installation, see separate installation documentation.

Waste Concept

- 1 Agilent recommends using the 6 L waste can with 1 Stay Safe cap GL45 with 4 ports (5043-1221) for optimal and safe waste disposal. If you decide to use your own waste solution, make sure that the tubes don't immerse in the liquid.



Hints for Successful Use of the Pump

- Always place the solvent cabinet with the solvent bottles on top of the quaternary pump (or at a higher level).
- When using salt solutions and organic solvents in the quaternary pump it is recommended to connect the salt solution to one of the bottom gradient valve ports and the organic solvent to one of the upper gradient valve ports. It is best to have the organic channel directly above the salt solution channel. Regular flushing of all MCGV channels with water is recommended to remove all possible salt deposits in the valve ports.
- Before operating the quaternary pump, flush the pump and vacuum degasser. This is especially recommended if it has been turned off for some time (for example, overnight) and volatile solvent mixtures are used in the channels.
- Prevent blocking of solvent inlet filters. Never use the pump without solvent inlet filter. Prevent the growth of algae, see [“Prevent Blocking of Solvent Filters”](#) on page 80).
- Regularly check the purge valve frit and column frit. A blocked purge valve frit can be identified by a black or yellow surface, deposits or by a pressure greater than 10 bar, when pumping distilled water at a rate of 5 mL/min with an open purge valve.
- When using the quaternary pump at low flow rates (for example, 0.2 mL/min) check all 1/16-inch fittings for any signs of leaks.
- Whenever exchanging the pump seals the purge valve frit should be exchanged, too.
- When using buffers or other salt solutions, flush the system with water before switching it off. The seal wash option should be used when salt concentrations of 0.1 M or higher will be used for long time periods.
- Check the pump pistons for scratches when changing the piston seals. Scratched pistons will cause micro leaks and will decrease the lifetime of the seal.
- Pressurize the system according to the wear in procedure after changing the piston seals (see [“Maintenance of a Pump Head Without Seal Wash Option”](#) on page 151).
- Consider recommendations given in the solvent information section, see [“Solvent Information”](#) on page 69.

Setting up the Pump with the G4208A Instant Pilot

Generic operation of the G4208A Instant Pilot is covered in the Agilent Instant Pilot G4208A User's Guide (G4208-90006). Details about setting up module specific parameters can be found in the Instant Pilot online help.

The pump parameters are described in detail in “[Overview](#)” on page 60.

3 Using the Pump

Setting up the Pump with the Instrument Control Interface

Setting up the Pump with the Instrument Control Interface

Overview

Parameters described in following sections is offered by the instrument control interface and can usually be accessed through Agilent instrument control software. For details, please refer to manuals and online help of respective user interfaces.

Instrument Configuration

Use the **Instrument Configuration** dialog box to examine and, if necessary, modify your instrument configuration. The **Configurable Modules** panel contains a list of all modules available for configuration. The **Selected Modules** panel contains the list of configured modules.

Auto Configuration: Under **Communication settings**, select either the **Host Name** option or the **IP address** option and enter the appropriate value for the host computer to enable automatic detection of the hardware configuration. The system configures the instrument automatically with no further manual configuration necessary.

The Quaternary Pump configuration parameters are in two sections:

- **Communication**
- **Options**

Communication: The parameters in this dialog box are detected automatically during autoconfiguration.

- **Device name,**
- **Type ID,**
- **Serial number,**
- **Firmware revision,**
- Button **Connection settings**

Options:

- **Pressure Unit:**
select the pressure units from the drop-down list (bar, psi or MPa).
- **External contacts board installed:**
This check box is marked to indicate that a BCD/external contacts board has been detected during autoconfiguration.
- **Seal wash installed:**
This check box is marked to indicate that an optional seal wash has been detected during autoconfiguration.

Please refer to the online help of your user interface for more detailed information.

The Pump User Interface (Dashboard Panel)

Module Graphic

The items in the pump graphic have the following meaning and function:



Indicates that an External Contacts board is installed.



The level of solvent in the bottle is denoted by the green area; when the solvent level falls below the specified volume, the area turns yellow; when the bottle is empty, the area turns red. Clicking on the solvent bottle displays the **Bottle Fillings** dialog box. The tooltip for the bottle shows the solvent name.



The pressure setpoints. The red line shows the current maximum pressure limit; the green area shows the current pressure (also shown as text).

The current solvent flow rate (in mL/min) is displayed above the pressure display.

Instrument Signals

The following pump signals are displayed:

Table 9	Pump signals (isocratic pump)
Flow	The current solvent flow rate (in mL/min).
Pressure	The current pump pressure (in bar, psi or MPa, see “Instrument Configuration” on page 61).
Ripple	The current ripple (in %).
Pressure Limit	The current maximum pressure limit.

Table 10 Pump signals (quaternary pump)

Flow	The current solvent flow rate (in mL/min).
Pressure	The current pump pressure (in bar, psi or MPa, see “ Instrument Configuration ” on page 61).
Tuning	Indicates the tuning efforts of 1290 Infinity pumps. For pumps operating as expected, the signal should stay in a range of -1 to +1 within the full scale of -2 to +2.
Pressure Limit	The current maximum pressure limit.
Composition A:B	The contributions of channels A and B to the current solvent composition.
Composition C:D	The contributions of channels C and D to the current solvent composition.

Context Menu

The context menu of the dashboard panel contains the following commands:



Control

Displays the pump's **Control** dialog box.



Method

Displays the pump's **Method Setup** dialog box.

Set Error Method

Sets the method that is loaded if an error occurs to the method that is currently available in the hardware.

Identify Device

Causes the LED on the front of the module to blink for a few seconds.



Switch Pump On/Off

Toggles the status of the pump, on or off.

Bottle Fillings

Displays the **Bottle Fillings** dialog box.

3 Using the Pump

Setting up the Pump with the Instrument Control Interface

Control Settings

The pump control parameters are in three sections:

- **Pump**
- **Seal Wash**
- **Automatic Turn On**

Table 11 Pump control parameters

Parameter	Limits	Description
Pump		Enables you to switch the pump On , Off or to a Standby condition. In the Standby condition, the pump motor is still active, and when the pump is switched on again, does not need to be re-initialized.
Seal Wash		<p>The seal wash can be set up to be run once (Single wash) or periodically (Periodic).</p> <ul style="list-style-type: none">• Off: no seal wash is used.• Single wash: the seal will be purged for a specified time.• Periodic: a periodic wash will be applied for a defined period in minutes. <p>The option is available only when the pump has seal wash capability. The seal wash capability is detected by the module itself. If seal wash is installed, it is recommended to use it in order to increase the primary seal lifetime.</p>
Automatic Turn On		Module can be turned on at a specified date/time. This feature can only be used if the module power switch is turned on.

Method Parameter Settings

The pump method setup parameters are in eight sections:

- **Flow**
- **Solvent(s)**
- **Stoptime**
- **Posttime**
- **Pressure Limits**
- **Timetable**
- **Advanced**

Table 12 Method parameters

Parameter	Limits	Description
Flow	≤200 bar: 0.0 – 10.00 mL/min in steps of 0.001 > 200 bar: 0.0 – 5.00 mL/min in steps of 0.001.	The flow is the rate of movement of eluent along the column. It is important that the flow rate is kept constant to ensure precise retention time, and peak measurements. Variations in flow rate can occur as a result of the partial failure of the pumping system, air in the pumping system, a change in the mobile phase viscosity or a temperature change.
Solvent(s)		<i>Isocratic Pump:</i> The text box allows you to type a brief description of the solvent. <i>Quaternary Pump:</i> You can set the percentages of solvents B, C and D to any value from 0 through 100 %. Solvent A always delivers the remaining volume: 100 - (%B + %C + %D). The check boxes allows you to turn the solvent channels on (checked) or off (cleared). The text boxes allow you to type a brief description of each of the solvents.
Stoptime	0.01 – 99999 minor As Injector/No Limit (an infinite run time).	The stoptime sets a time limit for your analysis. After the stoptime, all gradients are stopped and the pump parameters return to their initial values. The pump can be used as a stoptime master for the complete analytical system. The pump also stops the detectors if they have a No Limit stoptime setting. If no limit is given, a method will have to be stopped manually.
Posttime	0.01 – 99999 minor Off (0.0 min).	Your instrument remains in a not ready state during the posttime to delay the start of the next analysis. You can use the Posttime to allow your column to equilibrate after changes in solvent composition (for example after gradient elution).

3 Using the Pump

Setting up the Pump with the Instrument Control Interface

Table 12 Method parameters

Parameter	Limits	Description
Pressure Limits	Max: 600 bar (8700 psi) for flow rates up to 5 mL/min. 200 bar (2900 psi) for flow rates > 5 mL/min. Min: any value between 0 and the upper pressure limit setting.	Sets the maximum and minimum pressure limits for the pump. <ul style="list-style-type: none">• Max is the maximum pressure limit at which the pump will switch itself off, protecting the analytical system against over-pressure.• Min is the minimum limit at which the pump will switch itself off, for example, if any solvent reservoir is empty, this prevents system damage by pumping air.
Timetable		See “Timetable Settings” on page 68
Advanced		See “Advanced Settings” on page 67

Advanced Settings

The pump advanced method setup parameters are in four sections:

- **Minimum Stroke**
- **Compressibility**
- **Maximum Flow Gradient**
- **Primary Channel** (Quaternary Pump only)

Table 13 Advanced method parameters

Parameter	Limits	Description
Minimum Stroke	20 – 100 μ L	The Stroke Volume is used for optimizing between performance of the module and seal life time. For performance a low stroke volume is beneficial, as it divides disturbances into smaller packages, but a larger volume is extending the life time of the pump seals. If Automatic is activated, the pump tries to achieve an optimized stroke volume for the Jet Weaver geometry.
Compressibility	$40 \cdot 10^{-6}$ – $150 \cdot 10^{-6}$. Default compressibility value: $100 \cdot 10^{-6}$	The compressibility of the mobile phase has an effect on the performance of the pump. For best flow accuracy and mixing performance, you can set the parameter according to the mobile phase being used.
Maximum Flow Gradient	0.1 – 100 mL/min/min Default value: 100 mL/min/min	You can set a limit on the rate of change of the solvent flow to protect your analytical column.
Primary Channel (Quaternary pump only)		Using Automatic is recommended. The primary channel can be specified as A to D for optimizing highly specific methods. It is split up to deliver the first and last solvent package created by the MCGV in order to optimize composition precision. The primary channel does not change during a gradient, as long as the channel is used. Using Automatic chooses the channel with the highest percentage at start conditions before a gradient.

3 Using the Pump

Setting up the Pump with the Instrument Control Interface

Timetable Settings

Use the **Timetable** to program changes in the pump parameters during the analysis by entering a time in the **Time** field and appropriate values in the following fields of the timetable. Changes in flow rate occur linearly from either time zero or the time of the last defined change; other parameters change instantaneously at the time defined in the timetable.

Show **Advanced Timetable** toggles the timetable display between standard mode and advanced mode.

The following parameters can be changed:

- **Change Contacts**
- **Change Flow**
- **Change Max. Pressure Limit**
- **Change Solvent Composition** - You can only use solvents, which have been enabled in the solvents section.
- **Function centric view** - This checkbox allows you displaying parameter changes instead of a time table.

Solvent Information

Observe the following recommendations on the use of solvents.

- Follow recommendations for avoiding the growth of algae, see [“Algae Growth in HPLC Systems”](#) on page 79
- Small particles can permanently block capillaries and valves. Therefore, always filter solvents through 0.22 µm filters.
- Avoid or minimize the use of solvents that may corrode parts in the flow path. Consider specifications for the pH range given for different materials like flow cells, valve materials etc. and recommendations in subsequent sections.

Materials in Flow Path

Following materials are used in the flow path of this module:

Table 14 Materials in flow path (G7110B, G7111A, G7111B)

Part	Materials
Degasser chamber	TFE/PDD Copolymer, PFA (internal tubings), PEEK (inlets), FEP (tubings), ETFE (fittings)
MCGV	SST, PTFE
Passive inlet valve	SST, gold, sapphire, ruby, ceramic, PTFE
Active inlet valve	SST, gold, sapphire, ruby, ceramic, PTFE
Outlet valve	SST, gold, ruby, ZrO ₂ -based ceramic, tantalum
Adapter	SST, gold
Pump head (body)	SST
Pistons	Sapphire
Piston seals/wash seals	PTFE, SST (reversed phase) or UHMW-PE, SST (normal phase)
Pressure sensor	SST
Purge valve	SST, gold, PTFE, ceramic
Damping unit	SST, gold
Capillaries/fittings	SST
Tubings	PTFE

Table 15 Materials in flow path (G5654A)

Part	Materials
Degasser chamber	TFE/PDD Copolymer, PFA (internal tubings), PEEK (inlets), FEP (tubings), ETFE (fittings)
MCGV	Platinum-iridium, titanium, PTFE
Active inlet valve	Platinum-iridium, titanium, gold, sapphire, ruby, ceramic, PTFE
Outlet valve	Titanium, gold, ruby, ZrO ₂ -based ceramic, tantalum
Adapter	Titanium, gold
Pump head (body)	Titanium
Pistons	Sapphire
Piston seals/wash seals	PTFE, gold
Pressure sensor	Titanium
Purge valve	Titanium, gold, PTFE, ceramic
Damping unit	Titanium, gold
Capillaries/fittings	Titanium
Tubings	PTFE

Bio-inert Materials

For the Bio-inert LC system, Agilent Technologies uses highest quality materials in the flow path (also referred to as wetted parts), which are widely accepted by life science scientists, as they are known for optimum inertness to biological samples and ensure best compatibility with common samples and solvents over a wide pH range. Explicitly, the complete flow path is free of stainless steel and free of other alloys containing metals such as iron, nickel, cobalt, chromium, molybdenum or copper, which can interfere with biological samples. The flow downstream of the sample introduction contains no metals whatsoever.

Table 16 Used Bio-inert materials

Module	Materials
Agilent 1260 Infinity II Bio-inert Quaternary Pump (G5654A)	Titanium, gold, platinum-iridium, ceramic, ruby, PTFE, PEEK
Agilent 1260 Infinity II Bio-inert Multisampler (G5668A)	Upstream of sample introduction: <ul style="list-style-type: none"> • Titanium, gold, PTFE, PEEK, ceramic Downstream of sample introduction: <ul style="list-style-type: none"> • PEEK, ceramic
Agilent 1260 Infinity II Bio-inert Manual Injector (G5628A)	PEEK, ceramic
Agilent 1260 Infinity Bio-inert Analytical Fraction Collector (G5664A)	PEEK, ceramic, PTFE
Bio-inert Flow Cells:	
Standard flow cell bio-inert, 10 mm, 13 μ L, 120 bar (12 MPa) for MWD/DAD, includes Capillary Kit Flow Cells BIO (p/n G5615-68755) (G5615-60022) (for Agilent 1260 Infinity Diode Array Detectors DAD G1315C/D)	PEEK, ceramic, sapphire, PTFE
Bio-inert flow cell, 8 μ L, 20 bar (pH 1–12) includes Capillary Kit Flow Cells BIO (p/n G5615-68755) (G5615-60005) (for Agilent 1260 Infinity Fluorescence Detector FLD G1321B)	PEEK, fused silica, PTFE
Quick-Connect Heat Exchanger Bio-inert (G7116-60041) (for Agilent 1260 Infinity II Multicolumn Thermostat G7116A)	PEEK (steel-cladded)

Table 16 Used Bio-inert materials

Module	Materials
Bio-inert Valve heads (G4235A, G5631A, G5632A, G5639A)	PEEK, ceramic (Al ₂ O ₃ based)
Bio-inert Connection capillaries	Upstream of sample introduction: <ul style="list-style-type: none"> • Titanium Downstream of sample introduction: <ul style="list-style-type: none"> • Agilent uses stainless-steel-cladded PEEK capillaries, which keep the flow path free of steel and provide pressure stability to more than 600 bar.

NOTE

To ensure optimum bio-compatibility of your Agilent 1260 Infinity Bio-inert LC system, do not include non-inert standard modules or parts to the flow path. Do not use any parts that are not labeled as Agilent “Bio-inert”. For solvent compatibility of these materials, see “[Material Information](#)” on page 74.

Material Information

Materials in the flow path are carefully selected based on Agilent's experiences in developing highest quality instruments for HPLC analysis over several decades. These materials exhibit excellent robustness under typical HPLC conditions. For any special conditions, please consult the material information section or contact Agilent.

Disclaimer

Subsequent data were collected from external resources and are meant as a reference. Agilent cannot guarantee the correctness and completeness of such information. Data is based on compatibility libraries, which are not specific for estimating the long-term life time under specific but highly variable conditions of UHPLC systems, solvents, solvent mixtures and samples. Information can also not be generalized due to catalytic effects of impurities like metal ions, complexing agents, oxygen etc. Apart from pure chemical corrosion, other effects like electro corrosion, electrostatic charging (especially for non-conductive organic solvents), swelling of polymer parts etc. need to be considered. Most data available refers to room temperature (typically 20 – 25 °C, 68 – 77 °F). If corrosion is possible, it usually accelerates at higher temperatures. If in doubt, please consult technical literature on chemical compatibility of materials.

PEEK

PEEK (Polyether-Ether Ketones) combines excellent properties regarding biocompatibility, chemical resistance, mechanical and thermal stability. PEEK is therefore the material of choice for UHPLC and biochemical instrumentation.

It is stable in the specified pH range (for the Bio-inert LC system: pH 1 – 13, see bio-inert module manuals for details), and inert to many common solvents.

There is still a number of known incompatibilities with chemicals such as chloroform, methylene chloride, THF, DMSO, strong acids (nitric acid > 10 %, sulphuric acid > 10 %, sulfonic acids, trichloroacetic acid), halogenes or aqueous halogene solutions, phenol and derivatives (cresols, salicylic acid etc.).

When used above room temperature, PEEK is sensitive to bases and various organic solvents, which can cause it to swell. Under such conditions normal PEEK capillaries are very sensitive to high pressure. Therefore Agilent uses stainless-steel clad PEEK capillaries in bio-inert systems. The use of stainless steel clad PEEK capillaries keeps the flow path free of steel and ensures pressure stability to at least 600 bar. If in doubt, consult the available literature about the chemical compatibility of PEEK.

Polyimide

Agilent uses semi-crystalline polyimide for rotor seals in valves and needle seats in autosamplers. One supplier of polyimide is DuPont, which brands polyimide as Vespel, which is also used by Agilent.

Polyimide is stable in a pH range between 1 and 10 and in most organic solvents. It is incompatible with concentrated mineral acids (e.g. sulphuric acid), glacial acetic acid, DMSO and THF. It is also degraded by nucleophilic substances like ammonia (e.g. ammonium salts in basic conditions) or acetates.

Polyethylene (PE)

Agilent uses UHMW (ultra-high molecular weight)-PE/PTFE blends for yellow piston and wash seals, which are used in 1290 Infinity pumps and for normal phase applications in 1260 Infinity pumps.

Polyethylene has a good stability for most common inorganic solvents including acids and bases in a pH range of 1 to 12.5. It is compatible to many organic solvents used in chromatographic systems like methanol, acetonitrile and isopropanol. It has limited stability with aliphatic, aromatic and halogenated hydrocarbons, THF, phenol and derivatives, concentrated acids and bases. For normal phase applications, the maximum pressure should be limited to 200 bar.

Tantalum (Ta)

Tantalum is inert to most common HPLC solvents and almost all acids except fluoric acid and acids with free sulfur trioxide. It can be corroded by strong bases (e.g. hydroxide solutions > 10 %, diethylamine). It is not recommended for the use with fluoric acid and fluorides.

Stainless Steel (ST)

Stainless steel is inert against many common solvents. It is stable in the presence of acids and bases in a pH range of 1 to 12.5. It can be corroded by acids below pH 2.3. It can also corrode in following solvents:

- Solutions of alkali halides, their respective acids (for example, lithium iodide, potassium chloride, and so on) and aqueous solutions of halogens.
- High concentrations of inorganic acids like nitric acid, sulfuric acid and organic solvents especially at higher temperatures (replace, if your chromatography method allows, by phosphoric acid or phosphate buffer which are less corrosive against stainless steel).
- Halogenated solvents or mixtures which form radicals and/or acids, for example:

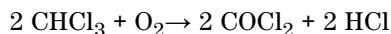

This reaction, in which stainless steel probably acts as a catalyst, occurs quickly with dried chloroform if the drying process removes the stabilizing alcohol.

- Chromatographic grade ethers, which can contain peroxides (for example, THF, dioxane, di-isopropylether). Such ethers should be filtered through dry aluminium oxide which adsorbs the peroxides.
- Solutions of organic acids (acetic acid, formic acid, and so on) in organic solvents. For example, a 1 % solution of acetic acid in methanol will attack steel.
- Solutions containing strong complexing agents (for example, EDTA, ethylene diamine tetra-acetic acid).
- Mixtures of carbon tetrachloride with 2-propanol or THF.

Titanium (Ti)

Titanium is highly resistant to oxidizing acids (for example, nitric, perchloric and hypochlorous acid) over a wide range of concentrations and temperatures. This is due to a thin oxide layer on the surface, which is stabilized by oxidizing compounds. Non-oxidizing acids (for example, hydrochloric, sulfuric and phosphoric acid) can cause slight corrosion, which increases with acid concentration and temperature. For example, the corrosion rate with 3 % HCl (about pH 0.1) at room temperature is about 13 $\mu\text{m}/\text{year}$. At room temperature, titanium is resistant to concentrations of about 5 % sulfuric acid (about pH 0.3). Addition of nitric acid to hydrochloric or sulfuric acids significantly reduces corrosion rates. Titanium is sensitive to acidic metal chlorides like FeCl_3 or CuCl_2 . Titanium is subject to corrosion in anhydrous methanol, which can be avoided by adding a small amount of water (about 3 %). Slight corrosion is possible with ammonia > 10 %.

Diamond-Like Carbon (DLC)

Diamond-Like Carbon is inert to almost all common acids, bases and solvents. There are no documented incompatibilities for HPLC applications.

Fused silica and Quartz (SiO₂)

Fused silica is used in 1290 Infinity Flow Cells and capillaries. Quartz is used for classical flow cell windows. It is inert against all common solvents and acids except hydrofluoric acid and acidic solvents containing fluorides. It is corroded by strong bases and should not be used above pH 12 at room temperature. The corrosion of flow cell windows can negatively affect measurement results. For a pH greater than 12, the use of flow cells with sapphire windows is recommended.

Gold

Gold is inert to all common HPLC solvents, acids and bases within the specified pH range. It can be corroded by complexing cyanides and concentrated acids like aqua regia.

Zirconium Oxide (ZrO₂)

Zirconium Oxide is inert to almost all common acids, bases and solvents. There are no documented incompatibilities for HPLC applications.

Platinum/Iridium

Platinum/Iridium is inert to almost all common acids, bases and solvents. There are no documented incompatibilities for HPLC applications.

Fluorinated polymers (PTFE, PFA, FEP, FFKM)

Fluorinated polymers like PTFE (polytetrafluorethylene), PFA (perfluoroalkoxy) and FEP (fluorinated ethylene propylene) are inert to almost all common acids, bases, and solvents. FFKM is perfluorinated rubber, which is also resistant to most chemicals. As an elastomer, it may swell in some organic solvents like halogenated hydrocarbons.

TFE/PDD copolymer tubings, which are used in all Agilent degassers except G1322A, are not compatible with fluorinated solvents like Freon, Fluorinert, or Vertrel. They have limited life time in the presence of Hexafluoroisopropanol (HFIP). To ensure the longest possible life with HFIP, it is best to dedicate a particular chamber to this solvent, not to switch solvents, and not to let dry out the chamber. For optimizing the life of the pressure sensor, do not leave HFIP in the chamber when the unit is off.

Sapphire, Ruby and Al₂O₃-based ceramics

Sapphire, ruby and ceramics based on aluminum oxide Al₂O₃ are inert to almost all common acids, bases and solvents. There are no documented incompatibilities for HPLC applications.

Algae Growth in HPLC Systems

The presence of algae in HPLC systems can cause a variety of problems that may be incorrectly diagnosed as instrument or application problems. Algae grow in aqueous media, preferably in a pH range of 4-8. Their growth is accelerated by buffers, for example phosphate or acetate. Since algae grow through photosynthesis, light will also stimulate their growth. Even in distilled water small-sized algae grow after some time.

Instrumental Problems Associated With Algae

Algae deposit and grow everywhere within the HPLC system causing:

- Blocked solvent filters or deposits on inlet or outlet valves resulting in unstable flow, composition or gradient problems or a complete failure of the pump.
- Small pore high pressure solvent filters, usually placed before the injector to plug resulting in high system pressure.
- PTFE frits blockage leading to increased system pressure.
- Column filters to plug giving high system pressure.
- Flow cell windows of detectors to become dirty resulting in higher noise levels (since the detector is the last module in the flow path, this problem is less common).

How to Prevent and-or Reduce the Algae Problem

- Always use freshly prepared solvents, especially use demineralized water which was filtered through about 0.2 μm filters.
- Never leave mobile phase in the instrument for several days without flow.
- Always discard old mobile phase.
- Use the amber solvent bottle (Solvent bottle, amber (9301-1450)) supplied with the instrument for your aqueous mobile phase.
- If possible add a few mg/l sodium azide or a few percent organic solvent to the aqueous mobile phase.

Prevent Blocking of Solvent Filters

Contaminated solvents or algae growth in the solvent bottle will reduce the lifetime of the solvent filter and will influence the performance of the module. This is especially true for aqueous solvents or phosphate buffers (pH 4 to 7). The following suggestions will prolong lifetime of the solvent filter and will maintain the performance of the module.

- Use a sterile, if possible amber, solvent bottle to slow down algae growth.
- Filter solvents through filters or membranes that remove algae.
- Exchange solvents every two days or refilter.
- If the application permits add 0.0001 – 0.001 M sodium azide to the solvent.
- Place a layer of argon on top of your solvent.
- Avoid exposure of the solvent bottle to direct sunlight.

NOTE

Never use the system without solvent filter installed.

Normal Phase Applications

Current passive inlet valves and outlet ball valves used with 1260 and 1290 Infinity pumps do not work well with applications using non-polar solvents as for normal phase applications (e.g. hexane and heptane). With such applications, pressure drops could be observed. They are a result of particles electrostatically charging up in insulating solvents and sticking to the balls inside the valves, such that the valves do not close properly any more after some time of use (can be hours).

For normal phase applications, a second type of valves is available, which has a design based on the existing one for 1260 and 1290 Infinity valves. These valves use a new material for valve balls, which is a conductive ceramic and replaces non-conductive ruby balls. The balls do not charge up electrostatically and show good performance in normal phase.

The valves are marked with N for non-polar or normal phase.

Agilent recommends using these valves for (and only for) normal phase applications.

CAUTION

Corrosion of valves

Normal phase balls/valves corrode quickly in aqueous solutions and acids (at or below pH 7).

→ Do not use normal phase valves in applications running with aqueous solutions.

The N-Valves have been tested successfully in using hexane at pressures below 100 bar; heptane can be used as a substitute for neurotoxic hexane.

Seals for Normal Phase Applications

For running normal phase applications on 1200 Infinity Series pumps, yellow PE seals are required, which exist as piston seals and wash seals. Seal wash is very uncommon for normal phase applications (no buffers needed), but wash seals are needed for seal wash pump heads.

1290 Infinity pumps use PE seals by default. In combination with ceramic pistons, PE seals are used for both reversed phase (1200 bar) and normal phase applications.

1260 Infinity pumps use sapphire pistons and black PTFE piston and wash seals by default (600 bar). Such PTFE seals create small wear particles in normal phase applications, which can clog valves and other parts in the flow path.

PE seals have a limited life time when used with normal phase solvents and sapphire pistons. Agilent recommends a maximum pressure of 200 bar for this combination, which shall also be applied for pressure tests.

Choice of Normal Phase Valves and Seals

Table 17 Recommended valves and seals for normal phase applications

	1260 Infinity	1290 Infinity
Inlet valves	1260 Infinity Inlet Valve Type N (G1312-60166)	1290 Infinity Inlet Valve Type N (G4220-60122) 1290 Infinity Quat Inlet Valve Type N (G4204-60122)
Outlet valves	1260 Infinity Outlet Valve Type N/SFC (G1312-60167)	1290 Infinity Outlet Valve Type N (G4220-60128)
Seals	PE seals (pack of 2) (0905-1420) Wash Seal PE (0905-1718)	



4 Optimizing Performance

Using the Degasser	84
Operational Hints for the Multi Channel Gradient Valve (MCGV)	85
When to use the Seal Wash Function	86
Choosing the Right Pump Seals	87
Optimize the Compressibility Compensation Setting	88

This chapter gives hints on how to optimize the performance or use additional devices.



Using the Degasser

The quaternary pump has a built-in degasser, which should always be included to the flow path.

Operational Hints for the Multi Channel Gradient Valve (MCGV)

In a mixture of salt solutions and organic solvent the salt solution might be well dissolved in the organic solvent without showing precipitations. However in the mixing point of the gradient valve, at the boundary between the two solvents, micro precipitation is possible. Gravity forces the salt particles to fall down. Normally the A channel of the valve is used for the aqueous/salt solution and the B channel of the pump is used for the organic solvent. If used in this configuration the salt will fall back into the aqueous solution and will be dissolved. When using the pump in a different configuration (e.g., D - salt solution, A - organic solvent) the salt can fall into the port of the organic solvent and may lead to performance problems.

NOTE

When using salt solutions and organic solvents it is recommended to connect the salt solution to one of the bottom ports of the MCGV and the organic solvent to one of the upper gradient valve ports. It is best to have the organic channel directly above the salt solution channel. Regular flushing with water of all MCGV channels is recommended to remove all possible salt deposits in the valve ports.

NOTE

Precipitations formed during the mixing of buffers and organic solvents which do not dissolve salts may cause a loss of pump performance (flow/retention time stability), a blockage or internal leak of the pump. Avoid the use of such solvent combinations, as they can cause irreproducible chromatographic results.

The use of an Inline filter (G1311-60006) can avoid or reduce such effects by filtering crystals and re-dissolving them over time.

4 Optimizing Performance

When to use the Seal Wash Function

When to use the Seal Wash Function

Highly concentrated buffer solutions will reduce the lifetime of the seals and pistons in your pump. The seal wash function allows to maintain the seal lifetime by flushing the back side of the seal with a wash solvent.

The seal wash function is strongly recommended when buffer concentrations of 0.1 M or higher will be used for long time periods in the pump.

The active seal wash upgrade can be ordered as G1398A.

The seal wash function comprises a support ring, secondary seal, gasket and seal holder for both piston sides. Place a wash bottle filled with 90 % water / 10 % isopropanol above the pump in the solvent cabinet. The peristaltic pump moves a flow through the pump head removing all possible buffer crystals from the back of the pump seal. This mixture prevents growth of algae or bacteria in the wash bottle and reduces the surface tension of the water.

Choosing the Right Pump Seals

The standard seal for the pump can be used for most applications. However applications that use normal phase solvents (for example, hexane) are not suited for the standard seal and require a different seal when used for a longer time in the pump.

For applications that use normal phase solvents (for example, hexane) we recommend using polyethylene pump seals (PE seals (pack of 2) (0905-1420)) and Wash Seal PE (0905-1718). For normal phase applications, these seals have less abrasion compared to the standard seals.

NOTE

Polyethylene seals have a limited pressure range of 0 – 200 bar. When used above 200 bar their lifetime is reduced significantly. *DO NOT* apply the seal wear-in procedure with PE seals.

Optimize the Compressibility Compensation Setting

The compressibility compensation default setting is 100×10^{-6} /bar for the pump. This setting represents an average value. Under normal conditions the default setting typically reduces the pressure pulsation to values below 1 % of system pressure that are sufficient for most applications and for all gradient analyses. The compressibility settings can be optimized by using the values for the various solvents described in [Table 18](#) on page 89. If the solvent in use is not listed in the compressibility tables, when using isocratic mixtures of solvents and if the default settings are not sufficient for your application the following procedure can be used to optimize the compressibility settings.

NOTE

When using mixtures of solvents it is not possible to calculate the compressibility of the mixture by interpolating the compressibility values of the pure solvents used in that mixture or by applying any other calculation. In these cases the following empirical procedure has to be applied to optimize your compressibility setting.

Inappropriate settings would mainly affect retention times of peaks eluted at the beginning of a gradient. Therefore optimize settings for the solvent at the beginning of the gradient. For mixtures containing up to 50 % water, use compressibility settings of water.

- 1 Start the pump with the required flow rate.
- 2 Before starting the optimization procedure, the flow must be stable. Check the tightness of the system with the pressure test.
- 3 Your pump must be connected to a data system or Instant Pilot with which the pressure and %-ripple can be monitored, or connect an external measurement device to the analog pressure output (see [“Electrical Connections”](#) on page 205)
- 4 Starting with a compressibility setting of $40 \cdot 10^{-6}$ /bar increase the value in steps of 10. Re-zero the signal display as required. The compressibility compensation setting that generates the smallest pressure ripple is the optimum value for your solvent composition. If ChemStation (classic view) is used and the ripple shown is positive, then the compressibility setting should be decreased. If it is negative, it should be increased.

Table 18 Solvent Compressibility

Solvent (pure)	Compressibility ($1 \cdot 10^{-6}$ /bar)
Acetone	126
Acetonitrile	115
Benzene	95
Carbon tetrachloride ¹	110
Chloroform ¹	100
Cyclohexane	118
Ethanol	114
Ethyl acetate	104
Heptane	120
Hexane	150
Isobutanol	100
Isopropanol	100
Methanol	120
1-Propanol	100
Toluene	87
Water	46

¹ Please check section "*Solvent Information*" for compatibility to your specific LC system.

4 Optimizing Performance

Optimize the Compressibility Compensation Setting



5 Troubleshooting and Diagnostics

User Interfaces 92

Agilent Lab Advisor Software 93

This chapter gives an overview about the troubleshooting and diagnostic features and the different user interfaces.



User Interfaces

Depending on the user interface, the available tests vary. Some descriptions are only available in the service manual.

Table 19 Test functions available vs. user interface

Test	Instant Pilot G4208A	Agilent Lab Advisor
System Pressure Test	Yes	Yes
Pump Leak Rate Test	No	Yes

Agilent Lab Advisor Software

The Agilent Lab Advisor Software is a standalone product that can be used with or without a chromatographic data system. Agilent Lab Advisor helps to manage the lab for high-quality chromatographic results by providing a detailed system overview of all connected analytical instruments with instrument status, Early Maintenance Feedback counters (EMF), instrument configuration information, and diagnostic tests. By the push of a button, a detailed diagnostic report can be generated. Upon request, the user can send this report to Agilent for a significantly improved troubleshooting and repair process.

The Agilent Lab Advisor software is available in two versions:

- Lab Advisor Basic
- Lab Advisor Advanced

Lab Advisor Basic is included with every Agilent 1200 Infinity Series and Agilent InfinityLab LC Series instruments.

The Lab Advisor Advanced features can be unlocked by purchasing a license key, and include real-time monitoring of instrument actuals, all various instrument signals, and state machines. In addition, all diagnostic test results, calibration results, and acquired signal data can be uploaded to a shared network folder. The Review Client included in Lab Advisor Advanced allows to load and examine the uploaded data no matter on which instrument it was generated. This makes Data Sharing an ideal tool for internal support groups and users who want to track the instrument history of their analytical systems.

The optional Agilent Maintenance Wizard Add-on provides an easy-to-use, step-by-step multimedia guide for performing preventive maintenance on Agilent 1200 Infinity and Agilent InfinityLab LC Series instruments.

The tests and diagnostic features that are provided by the Agilent Lab Advisor software may differ from the descriptions in this manual. For details, refer to the Agilent Lab Advisor software help files.

5 Troubleshooting and Diagnostics

Agilent Lab Advisor Software



6 Error Information

What Are Error Messages	97
General Error Messages	98
Timeout	98
Shutdown	99
Remote Timeout	99
Lost CAN Partner	100
Leak	100
Leak Sensor Open	101
Leak Sensor Short	101
Compensation Sensor Open	102
Compensation Sensor Short	102
Fan Failed	103
Open Cover	103
Cover Violation	104
ERI Messages	104
Module Error Messages	105
Solvent Zero Counter	105
Pressure Above Upper Limit	105
Pressure Below Lower Limit	106
Pressure Signal Missing	106
MCGV Fuse	107
AIV Fuse	107
Valve Failed (MCGV)	108
Motor-Drive Power	109
Temperature Limit Exceeded	110
Servo Restart Failed	111
Pump Head Missing	112
Index Limit	112



6 Error Information

Agilent Lab Advisor Software

Index Adjustment	113
Index Missing	113
Initialization Failed	114
Wait Timeout	115
Degasser: signal fail	116
Degasser: limit not reached	116
SSV Protection circuit triggered	117

This chapter describes the meaning of error messages, and provides information on probable causes and suggested actions how to recover from error conditions.

What Are Error Messages

Error messages are displayed in the user interface when an electronic, mechanical, or hydraulic (flow path) failure occurs which requires attention before the analysis can be continued (for example, repair, or exchange of consumables is necessary). In the event of such a failure, the red status indicator at the front of the module is switched on, and an entry is written into the module logbook.

If an error occurs outside a method run, other modules will not be informed about this error. If it occurs within a method run, all connected modules will get a notification, all LEDs get red and the run will be stopped. Depending on the module type, this stop is implemented differently. For example, for a pump the flow will be stopped for safety reasons. For a detector, the lamp will stay on in order to avoid equilibration time. Depending on the error type, the next run can only be started, if the error has been resolved, for example liquid from a leak has been dried. Errors for presumably single time events can be recovered by switching on the system in the user interface.

Special handling is done in case of a leak. As a leak is a potential safety issue and may have occurred at a different module from where it has been observed, a leak always causes a shutdown of all modules, even outside a method run.

In all cases, error propagation is done via the CAN bus or via an APG/ERI remote cable (see documentation for the APG/ERI interface).

General Error Messages

General error messages are generic to all Agilent series HPLC modules and may show up on other modules as well.

Timeout

Error ID: 0062

The timeout threshold was exceeded.

Probable cause

- 1** The analysis was completed successfully, and the timeout function switched off the module as requested.
- 2** A not-ready condition was present during a sequence or multiple-injection run for a period longer than the timeout threshold.

Suggested actions

- Check the logbook for the occurrence and source of a not-ready condition. Restart the analysis where required.
- Check the logbook for the occurrence and source of a not-ready condition. Restart the analysis where required.

Shutdown

Error ID: 0063

An external instrument has generated a shutdown signal on the remote line.

The module continually monitors the remote input connectors for status signals. A LOW signal input on pin 4 of the remote connector generates the error message.

Probable cause

- 1 Leak detected in another module with a CAN connection to the system.
- 2 Leak detected in an external instrument with a remote connection to the system.
- 3 Shut-down in an external instrument with a remote connection to the system.
- 4 The degasser failed to generate sufficient vacuum for solvent degassing.

Suggested actions

- Fix the leak in the external instrument before restarting the module.
- Fix the leak in the external instrument before restarting the module.
- Check external instruments for a shut-down condition.
- Check the vacuum degasser for an error condition. Refer to the *Service Manual* for the degasser or the pump that has the degasser built-in.

Remote Timeout

Error ID: 0070

A not-ready condition is still present on the remote input. When an analysis is started, the system expects all not-ready conditions (for example, a not-ready condition during detector balance) to switch to run conditions within one minute of starting the analysis. If a not-ready condition is still present on the remote line after one minute the error message is generated.

Probable cause

- 1 Not-ready condition in one of the instruments connected to the remote line.
- 2 Defective remote cable.
- 3 Defective components in the instrument showing the not-ready condition.

Suggested actions

- Ensure the instrument showing the not-ready condition is installed correctly, and is set up correctly for analysis.
- Exchange the remote cable.
- Check the instrument for defects (refer to the instrument's documentation).

Lost CAN Partner

Error ID: 0071

During an analysis, the internal synchronization or communication between one or more of the modules in the system has failed.

The system processors continually monitor the system configuration. If one or more of the modules is no longer recognized as being connected to the system, the error message is generated.

Probable cause

- 1 CAN cable disconnected.
- 2 Defective CAN cable.
- 3 Defective main board in another module.

Suggested actions

- Ensure all the CAN cables are connected correctly.
 - Ensure all CAN cables are installed correctly.
- Exchange the CAN cable.
- Switch off the system. Restart the system, and determine which module or modules are not recognized by the system.

Leak

Error ID: 0064

A leak was detected in the module.

The signals from the two temperature sensors (leak sensor and board-mounted temperature-compensation sensor) are used by the leak algorithm to determine whether a leak is present. When a leak occurs, the leak sensor is cooled by the solvent. This changes the resistance of the leak sensor which is sensed by the leak-sensor circuit on the main board.

Probable cause

- 1 Loose fittings.
- 2 Broken capillary.
- 3 Loose or leaking purge valve, inlet valve, or outlet valve.
- 4 Defective pump seals.

Suggested actions

- Ensure all fittings are tight.
- Exchange defective capillaries.
- Ensure pump components are seated correctly. If there are still signs of a leak, exchange the appropriate seal (purge valve, inlet valve, outlet valve).
- Exchange the pump seals.

Leak Sensor Open

Error ID: 0083

The leak sensor in the module has failed (open circuit).

The current through the leak sensor is dependent on temperature. A leak is detected when solvent cools the leak sensor, causing the leak-sensor current to change within defined limits. If the current falls outside the lower limit, the error message is generated.

Probable cause	Suggested actions
1 Leak sensor not connected to the Power Switch board.	Please contact your Agilent service representative.
2 Defective leak sensor.	Please contact your Agilent service representative.
3 Leak sensor incorrectly routed, being pinched by a metal component.	Please contact your Agilent service representative.
4 Power switch assembly defective	Please contact your Agilent service representative.

Leak Sensor Short

Error ID: 0082

The leak sensor in the module has failed (short circuit).

The current through the leak sensor is dependent on temperature. A leak is detected when solvent cools the leak sensor, causing the leak sensor current to change within defined limits. If the current increases above the upper limit, the error message is generated.

Probable cause	Suggested actions
1 Defective leak sensor.	Please contact your Agilent service representative.
2 Leak sensor incorrectly routed, being pinched by a metal component.	Please contact your Agilent service representative.
3 Power switch assembly defective	Please contact your Agilent service representative.

Compensation Sensor Open

Error ID: 0081

The ambient-compensation sensor (NTC) on the power switch board in the module has failed (open circuit).

The resistance across the temperature compensation sensor (NTC) on the power switch board is dependent on ambient temperature. The change in resistance is used by the leak circuit to compensate for ambient temperature changes. If the resistance across the sensor increases above the upper limit, the error message is generated.

Probable cause

- 1 Loose connection between the power switch board and the main board
- 2 Defective power switch assembly

Suggested actions

- Please contact your Agilent service representative.
- Please contact your Agilent service representative.

Compensation Sensor Short

Error ID: 0080

The ambient-compensation sensor (NTC) on the power switch board in the module has failed (open circuit).

The resistance across the temperature compensation sensor (NTC) on the power switch board is dependent on ambient temperature. The change in resistance is used by the leak circuit to compensate for ambient temperature changes. If the resistance across the sensor falls below the lower limit, the error message is generated.

Probable cause

- 1 Defective power switch assembly
- 2 Loose connection between the power switch board and the main board

Suggested actions

- Please contact your Agilent service representative.
- Please contact your Agilent service representative.

Fan Failed

Error ID: 0068

The cooling fan in the module has failed.

The hall sensor on the fan shaft is used by the main board to monitor the fan speed. If the fan speed falls below a certain limit for a certain length of time, the error message is generated.

This limit is given by 2 revolutions/second for longer than 5 seconds.

Depending on the module, assemblies (e.g. the lamp in the detector) are turned off to assure that the module does not overheat inside.

Probable cause	Suggested actions
1 Fan cable disconnected.	Please contact your Agilent service representative.
2 Defective fan.	Please contact your Agilent service representative.
3 Defective main board.	Please contact your Agilent service representative.

Open Cover

Error ID: 0205

The top foam has been removed.

The sensor on the main board detects when the top foam is in place. If the foam is removed, the fan is switched off, and the error message is generated.

Probable cause	Suggested actions
1 The top foam was removed during operation.	Please contact your Agilent service representative.
2 Foam not activating the sensor.	Please contact your Agilent service representative.
3 Defective sensor or main board.	Please contact your Agilent service representative.
4 Rear of the module is exposed to strong direct sunlight.	Ensure that the rear of module is not directly exposed to strong sunlight.

Cover Violation

Error ID: 7461

The top foam has been removed.

The sensor on the main board detects when the top foam is in place. If the foam is removed while the lamps are on (or if an attempt is made to switch on for example the lamps with the foam removed), the lamps are switched off, and the error message is generated.

Probable cause

- 1 The top foam was removed during operation.
- 2 Foam not activating the sensor.

Suggested actions

- Please contact your Agilent service representative.
- Please contact your Agilent service representative.

ERI Messages

Error ID: 11120 (+5 V) , 11121 (+25 V)

The ERI (Enhanced Remote Interface) provides two error events related to over current situations on the +5 V and +24 V lines.

Probable cause

- 1 The load on the ERI is too high.

Suggested actions

- Reduce the load.

Module Error Messages

These errors are pump specific.

Solvent Zero Counter

Error ID: 2055, 2524

Pump firmware version A.02.32 and higher allow to set solvent bottle fillings in the data system. If the volume level in the bottle falls below the specified value the error message appears when the feature is configured accordingly.

Probable cause	Suggested actions
1 Volume in bottle below specified volume.	Refill bottles and reset solvent counters.
2 Incorrect setting.	Make sure the limits are set correctly.

Pressure Above Upper Limit

Error ID: 2014, 2500

The system pressure has exceeded the upper pressure limit.

Probable cause	Suggested actions
1 Upper pressure limit set too low.	Ensure the upper pressure limit is set to a value suitable for the analysis.
2 Blockage in the flowpath (after the damper).	Check for blockage in the flow path. The following components are particularly subject to blockage: inline filter frit, needle (autosampler), seat capillary (autosampler), sample loop (autosampler), column frits and capillaries with small internal diameters (e.g. 50 µm ID).
3 Defective damper.	Please contact your Agilent service representative.
4 Defective main board.	Please contact your Agilent service representative.

Pressure Below Lower Limit

Error ID: 2015, 2501

The system pressure has fallen below the lower pressure limit.

Probable cause

- 1 Lower pressure limit set too high.
- 2 Air bubbles in the mobile phase.
- 3 Leak.
- 4 Defective damper.
- 5 Defective main board.

Suggested actions

- Ensure the lower pressure limit is set to a value suitable for the analysis.
- Make sure that the degasser is in flow path and works correctly. Purge the module.
 - Ensure solvent inlet filters are not blocked.
 - Inspect the pump head, capillaries and fittings for signs of a leak.
 - Purge the module. Run a pressure test to determine whether the seals or other module components are defective.
- Please contact your Agilent service representative.
- Please contact your Agilent service representative.

Pressure Signal Missing

Error ID: 2016

The pressure signal of the damper is missing.

The pressure signal of the damper must be within a specific voltage range. If the pressure signal is missing, the processor detects a voltage of approximately -120 mV across the damper connector.

Probable cause

- 1 Damper disconnected.
- 2 Defective damper.

Suggested actions

- Please contact your Agilent service representative.
- Please contact your Agilent service representative.

MCGV Fuse

Error ID: 2043

Valve Fuse 0: Channels A and B

Valve Fuse 1: Channels C and D

The gradient valve in the quaternary pump has drawn excessive current causing the electronic fuse to open.

Probable cause

- 1 Defective gradient valve.
- 2 Defective connection cable (front panel to main board).
- 3 Defective main board.

Suggested actions

- Restart the quaternary pump. If the error message appears again, exchange the gradient valve.
- Please contact your Agilent service representative.
- Please contact your Agilent service representative.

AIV Fuse

Error ID: 2044

The active-inlet valve in the module has drawn excessive current causing the inlet-valve electronic fuse to open.

Probable cause

- 1 Defective active inlet valve.
- 2 Defective connection cable (front panel to main board).
- 3 Defective main board.

Suggested actions

- Restart the module. If the error message appears again, exchange the active inlet valve.
- Please contact your Agilent service representative.
- Please contact your Agilent service representative.

Valve Failed (MCGV)

Error ID: 2040

Valve 0 Failed: valve A

Valve 1 Failed: valve B

Valve 2 Failed: valve C

Valve 3 Failed: valve D

One of the valves of the multi-channel gradient valve has failed to switch correctly.

The processor monitors the valve voltage before and after each switching cycle. If the voltages are outside expected limits, the error message is generated.

Probable cause

- 1 Gradient valve disconnected.
- 2 Connection cable (inside instrument) not connected.
- 3 Connection cable (inside instrument) defective.
- 4 Gradient valve defective.

Suggested actions

- Ensure the gradient valve is connected correctly.
- Please contact your Agilent service representative.
- Please contact your Agilent service representative.
- Exchange the gradient valve.

Motor-Drive Power

Error ID: 2041, 2042

The current drawn by the pump motor exceeded the maximum limit.

Blockages in the flow path are usually detected by the pressure sensor in the damper, which result in the pump switching off when the upper pressure limit is exceeded. If a blockage occurs before the damper, the pressure increase cannot be detected by the pressure sensor and the module will continue to pump. As pressure increases, the pump drive draws more current. When the current reaches the maximum limit, the module is switched off, and the error message is generated.

Probable cause	Suggested actions
1 Flow path blockage in front of the damper.	Ensure the capillaries and frits between the pump head and damper inlet are free from blockage.
2 Blocked (passive or active) inlet valve.	Exchange the (passive or active) inlet valve.
3 Blocked outlet valve.	Exchange the outlet valve.
4 High friction (partial mechanical blockage) in the pump drive assembly.	Remove the pump-head assembly. Ensure there is no mechanical blockage of the pump-head assembly or pump drive assembly.
5 Defective pump drive assembly.	Please contact your Agilent service representative.
6 Defective main board.	Please contact your Agilent service representative.

Temperature Limit Exceeded

Error ID: 2517

The temperature of one of the motor-drive circuits is too high.

The processor continually monitors the temperature of the drive circuits on the main board. If excessive current is being drawn for long periods, the temperature of the circuits increases. If the temperature exceeds the upper limit, the error message is generated.

Probable cause

- 1 High friction (partial mechanical blockage) in the pump drive assembly.
- 2 Partial blockage of the flowpath in front of the damper.
- 3 Defective pump drive assembly.
- 4 Defective main board.

Suggested actions

- Remove the pump-head assembly. Ensure there is no mechanical blockage of the pump-head assembly or pump drive assembly.
- Ensure the outlet valve is not blocked.
- Please contact your Agilent service representative.
- Please contact your Agilent service representative.

Servo Restart Failed

Error ID: 2201, 2211

The pump motor in the module was unable to move into the correct position for restarting.

When the module is switched on, the first step is to switch on the C phase of the variable reluctance motor. The rotor should move to one of the C positions. The C position is required for the servo to be able to take control of the phase sequencing with the commutator. If the rotor is unable to move, or if the C position cannot be reached, the error message is generated.

Probable cause	Suggested actions
1 Disconnected or defective cable.	Please contact your Agilent service representative.
2 Blocked (passive or active) inlet valve.	Exchange the (passive or active) inlet valve.
3 Mechanical blockage of the module.	Remove the pump-head assembly. Ensure there is no mechanical blockage of the pump-head assembly or pump drive assembly.
4 Defective pump drive assembly.	Please contact your Agilent service representative.
5 Defective main board.	Please contact your Agilent service representative.

Pump Head Missing

Error ID: 2202, 2212

The pump-head end stop in the pump was not found.

When the pump restarts, the metering drive moves forward to the mechanical end stop. Normally, the end stop is reached within 20 s, indicated by an increase in motor current. If the end point is not found within 20 s, the error message is generated.

Probable cause

- 1 Pump head not installed correctly (screws not secured, or pump head not seated correctly).
- 2 Broken piston.

Suggested actions

- Install the pump head correctly. Ensure nothing (e.g. capillary) is trapped between the pump head and body.
- Exchange the piston.

Index Limit

Error ID: 2203, 2213

The time required by the piston to reach the encoder index position was too short (pump).

During initialization, the first piston is moved to the mechanical stop. After reaching the mechanical stop, the piston reverses direction until the encoder index position is reached. If the index position is reached too fast, the error message is generated.

Probable cause

- 1 Irregular or sticking drive movement.
- 2 Defective pump drive assembly.

Suggested actions

- Remove the pump head, and examine the seals, pistons, and internal components for signs of wear, contamination or damage. Exchange components as required.
- Please contact your Agilent service representative.

Index Adjustment

Error ID: 2204, 2214

The encoder index position in the module is out of adjustment.

During initialization, the first piston is moved to the mechanical stop. After reaching the mechanical stop, the piston reverses direction until the encoder index position is reached. If the time to reach the index position is too long, the error message is generated.

Probable cause

- 1 Irregular or sticking drive movement.
- 2 Defective pump drive assembly.

Suggested actions

- Remove the pump head, and examine the seals, pistons, and internal components for signs of wear, contamination or damage. Exchange components as required.
- Please contact your Agilent service representative.

Index Missing

Error ID: 2205, 2215, 2505

The encoder index position in the module was not found during initialization.

During initialization, the first piston is moved to the mechanical stop. After reaching the mechanical stop, the piston reverses direction until the encoder index position is reached. If the index position is not recognized within a defined time, the error message is generated.

Probable cause

- 1 Disconnected or defective encoder cable.
- 2 Defective pump drive assembly.

Suggested actions

- Please contact your Agilent service representative.
- Please contact your Agilent service representative.

Initialization Failed

Error ID: 2207, 2217

The module failed to initialize successfully within the maximum time window.

A maximum time is assigned for the complete pump-initialization cycle. If the time is exceeded before initialization is complete, the error message is generated.

Probable cause

- 1** Blocked (passive or active) inlet valve.
- 2** Defective pump drive assembly.
- 3** Defective main board.

Suggested actions

- Exchange the (passive or active) inlet valve.
- Please contact your Agilent service representative.
- Please contact your Agilent service representative.

Wait Timeout

Error ID: 2053

When running certain tests in the diagnostics mode or other special applications, the pump must wait for the pistons to reach a specific position, or must wait for a certain pressure or flow to be reached. Each action or state must be completed within the timeout period, otherwise the error message is generated.

Possible Reasons for a Wait Timeout:

- Pressure not reached.
- Pump channel A did not reach the delivery phase.
- Pump channel B did not reach the delivery phase.
- Pump channel A did not reach the take-in phase.
- Pump channel B did not reach the take-in phase.
- Solvent volume not delivered within the specified time.

Probable cause

- 1** Purge valve open.
- 2** Leak at fittings, purge valve, active inlet valve, outlet valve or piston seals.
- 3** Flow changed after starting test.
- 4** Defective pump drive assembly.

Suggested actions

- Ensure that purge valve is closed.
- Ensure pump components are seated correctly. If there are still signs of a leak, exchange the appropriate seal (purge valve, active inlet valve, outlet valve, piston seal).
 - Exchange defective capillaries.
- Ensure correct operating condition for the special application in use.
- Please contact your Agilent service representative.

Degasser: signal fail

Error ID: 2243

The pump board gets no or wrong pressure signals from the built-in degasser.

Parameters:

- 0: ADC failure
- 1: ADC cannot convert pressure signal
- 2: Measured pressure out of range (negative or higher than 1021 hPa)

Probable cause

- 1 Degasser board defect, missing or not connected to the pump main board.
- 2 Degasser sensor defect or not connected to degasser board
- 3 If parameter is 0 and the LED on the degasser board blinks, it is probably because of a defect pump main board.

Suggested actions

- Please contact your Agilent service representative.
- Please contact your Agilent service representative.
- Please contact your Agilent service representative.

Degasser: limit not reached

Error ID: 2244

This error is thrown, if the degasser does not become ready after 8 min, i.e. is higher than 180 mbar.

Probable cause

- 1 Liquid in degasser tubing.
- 2 Leak in degasser tubing or chamber.
- 3 Degasser vacuum pump defect.

Suggested actions

- Please contact your Agilent service representative.
- Please contact your Agilent service representative.
- Please contact your Agilent service representative.

SSV Protection circuit triggered

Error ID: 2049

The protection circuit of SSV has switched OFF the valve. During initialization, the processor checks the presence of the SSV connector. If a defective valve or a wrong connection is detected the error message is generated.

Probable cause

- 1 Wrong valve connected.
- 2 Defective Solvent Selection Valve.
- 3 Defective main board

Suggested actions

- Check if the correct valve is connected to the correct port.
- Change the Solvent Selection Valve.
- Contact your Agilent service representative.

6 Error Information

Module Error Messages



7 Test Functions and Calibration

Introduction	120
System Pressure Test	121
Running the Test	123
Evaluating the Results	124
Potential Causes of System Pressure Test Failure	125
Leak Rate Test	126
Running the Test	128
Evaluating the Results	129
Potential Causes of Leak Rate Test Failure	130

This chapter describes the tests for the module.



Introduction

Following tests are available in Lab Advisor:

- **System Pressure Test**
- **Leak Rate Test**

All four pumps are available with LabAdvisor B.02.08.

System Pressure Test

Introduction

The **System Pressure Test** is used for checking the tightness of the LC system and identifying leaks between the pump and a position in the flow path following the pump blocked by a blank nut.

System requirements

Minimum software revisions:

- Lab Advisor B.02.08

Minimum firmware revision: D.07.01.

Test Principle

A solvent can be chosen from available solvent channels and a maximum pressure can be defined at which the test will be run. In contrast to older revisions of this test, any solvent can be used.

Before the test, the pump and system are flushed with solvent in order to remove air bubbles, as air bubbles are compressed during the test and therefore would appear as leaks. Using a degasser is highly recommended. Then the flow path is blocked by a blank nut at any position between the purge valve and the column outlet.

7 Test Functions and Calibration

System Pressure Test

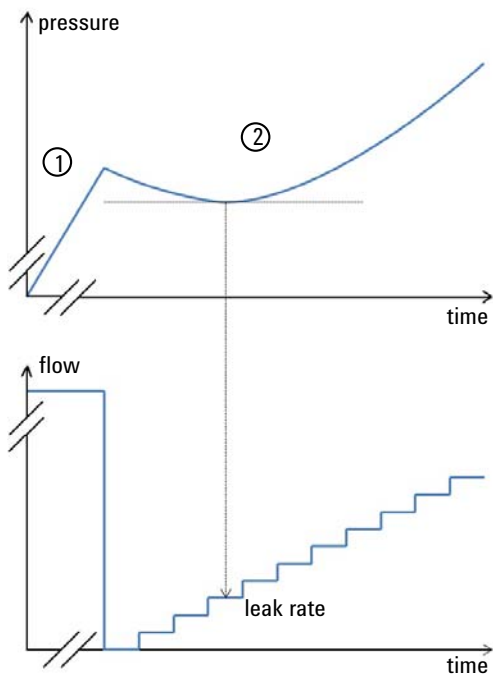

In the first phase of the test, the pump delivers flow at a rate of 200 $\mu\text{L}/\text{min}$ until a pressure of 50 bar below the defined maximum pressure is reached. In the second phase, the pump delivers a small flow which is increased stepwise. If there is a leak in the system, the pressure will drop initially, as the low flow cannot compensate the leak flow. As soon as the pump flow rate exceeds the leak flow rate, the pressure will increase again and the test is stopped at about 20 bar below the maximum pressure. The point in phase 2, where the lowest pressure is reached and stays constant for a short time corresponds to the leak rate, that is provided as a test result. A leak rate smaller than 3 $\mu\text{L}/\text{min}$ is good enough for operating the pump reliably.

Running the Test

Parts required	p/n	Description
	01080-83202	Blank nut

CAUTION

Damage to pressure sensitive parts

Even columns that are suitable for high pressures are sensitive to pressure drops that occur during this test.

- Do not include any pressure sensitive parts to the flow path and choose a maximum pressure that is compatible to your system. For example, do not include columns, a standard pressure flow cell (up to 20 bar) or a 400 bar autosampler to a 600 bar pressure test.

Running the test from the Agilent Lab Advisor

- 1 Select the **System Pressure Test** from the **Test Selection** menu.
- 2 Start the test and follow the instructions.

NOTE

Make sure to release the pressure by slowly opening the purge valve when the test has finished.

“Evaluating the Results” on page 124 describes the evaluation and interpretation of the **System Pressure Test** results. For detailed instructions refer to the Agilent Lab Advisor software.

Evaluating the Results

The test fails, if the leak rate between pump and blank nut is higher than the limit of 3 $\mu\text{L}/\text{min}$.

If the **System Pressure Test** fails:

- Ensure that all fittings between the pump and the blank nut are tight.
- Repeat the test.

NOTE

Often it is only a damaged blank nut itself (poorly shaped from overtightening) that causes a failure of the test. Before investigating on any other possible sources of failure make sure that the blank nut you are using is in good condition and properly tightened!

If the test fails again, insert the blank nut at the outlet of the previous module in the stack (e.g. autosampler outlet if TCC has been tested before), and repeat the test. Exclude each module one by one to determine which module is leaking.

If the pump is determined to be the source of the leak, run the **Pump Leak Rate Test**.

Potential Causes of System Pressure Test Failure

System Pressure Test failed

The test will fail, if the sum of all leaks in the system (pump, autosampler or column compartment and connections) exceeds the test limit. After isolating and fixing the cause of the leak, repeat the **System Pressure Test** to confirm the system is pressure tight.

Probable cause	Suggested actions
1 Purge valve open.	Close the purge valve.
2 Loose or leaky fittings.	Tighten the fitting or exchange the capillary.
3 Pump: Damaged pump seals or pistons.	Run the Leak Rate Test to confirm the leak.
4 Loose purge valve.	Tighten the purge valve nut (14 mm wrench).
5 Autosampler: Loose or leaky fitting.	Tighten or exchange the fitting or capillary.
6 Autosampler: Rotor seal (injection valve).	Exchange the rotor seal.
7 Autosampler: Damaged metering seal or piston.	Exchange the metering seal. Check the piston for scratches. Exchange the piston if required.
8 Autosampler: Needle seat.	Exchange the needle seat.
9 Column compartment: Loose or leaky fitting.	Tighten or exchange the fitting or capillary.
10 Column compartment: Rotor seal in optional valve.	Exchange the rotor seal.

Leak Rate Test

Introduction

The **Leak Rate Test** is used for verifying the internal tightness of the pump and helps identifying parts which may have caused a leak.

System requirements

Minimum software revisions:

- Lab Advisor B.02.08

Minimum firmware revisions:

- D.07.01

NOTE

This test does not work in emulation mode. In case of an emulated module, convert to the original type first (see [“Replacing the Module Firmware”](#) on page 168).

Test Principle

A solvent can be chosen from available solvent channels and a maximum target pressure can be defined at which the test will be run. Typically, this is the maximum pressure specified for the pump. The test can be run with any solvent compatible to the pump.

Before the test, the pump is flushed with solvent in order to remove air bubbles, as air bubbles are compressed during the test and therefore would appear as leaks. Using a degasser is highly recommended.

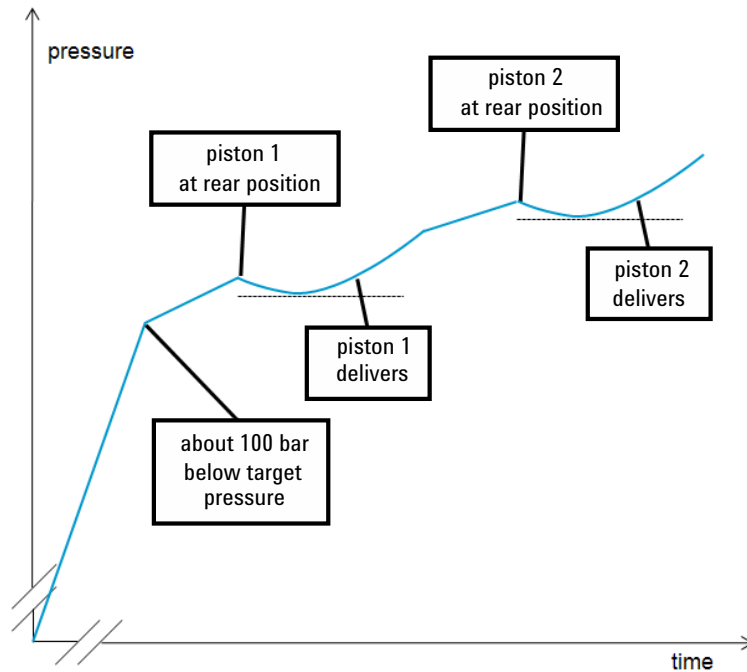

Initially, the pressure is increased to about 100 bar below the target pressure, which has been set for the test.

Then piston 1 is brought to its rear position. An increasing flow is delivered by piston 1. In case of a leak, the pressure will drop initially as long as the flow rate delivered by the piston is lower than the leak rate. As soon as the flow rate of the piston exceeds the leak rate, the measured pressure will increase again. Therefore the minimum pressure of that curve segment corresponds to the flow and leak rate at that time and the leak rate is measured. Compare to the description of the system pressure test (“[System Pressure Test](#)” on page 121).

Subsequently, piston 2 is moved to its rear position, then piston 2 delivers and the measurement is done as described for piston 1.

For a binary pump (G1312B/C, K1312B), the test is run for both pump heads for channels A and B.

7 Test Functions and Calibration

Leak Rate Test

Running the Test

Parts required	p/n	Description
	01080-83202	Blank nut

Running the test from the Agilent Lab Advisor

- 1 Select the **Leak Rate Test** from the **Test Selection** menu.
- 2 Start the test and follow the instructions.

NOTE

Make sure to release the pressure by slowly opening the purge valve when the test has finished.

Evaluating the Results

Results of the leak rate test are the leak rates measured for pistons 1 and 2 as described for the test principle. If any of the leak rates exceeds 3 $\mu\text{L}/\text{min}$, the test will fail.

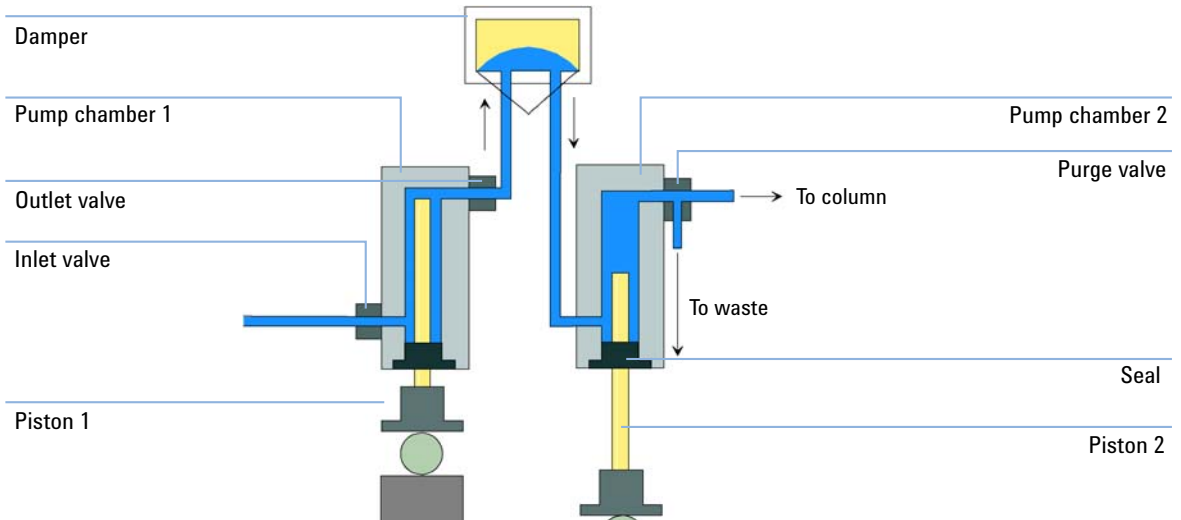

Potential Causes of Leak Rate Test Failure

Secondary Leak

If a leak is found for movement of piston 2 (secondary leak), the following reasons are possible:

Probable cause	Suggested actions
1 System not flushed properly	Flush system for several minutes
2 Degassing efficiency is low	Check degasser performance
3 Purge valve not closed or defect	Check purge valve
4 Blank nut not installed tightly	Tighten or replace blank nut
5 Outlet valve leaking (read below)	Replace outlet valve
6 Leak at piston 2 or seal in chamber 2	Inspect piston, replace piston and/or seal

Primary Leak

If a leak is found for movement of piston 1 (primary leak), any leak described for piston movement 2 will cause a failure for piston 1 as well, as the liquid can move through the outlet valve to chamber 2. Such cases need to be identified as described before. Additionally, following causes are possible:

Probable cause	Suggested actions
1 Leak at piston 1 or seal in chamber 1	Inspect piston, replace piston and/or seal
2 Leak at inlet valve	Replace inlet valve or inlet valve cartridge (AIV only)

Internal Outlet Valve Leak

A leak of the outlet valve will be identified separately (internal outlet valve leak) by calculating the difference between leak rate 1 and leak rate 2. If the second leak rate is higher than the first one, this is due to a flow back through the outlet valve.

Probable cause

- 1 Leak at outlet valve

Suggested actions

Replace the part which has failed and re-run the test.

7 Test Functions and Calibration

Leak Rate Test



8 Maintenance

Introduction to Maintenance and Repair	134
Warnings and Cautions	135
Overview of Maintenance and Repair	136
Cleaning the Module	137
Remove and Install Doors	138
Checking and Replacing the Solvent Filter	139
Exchange the Passive Inlet Valve	140
Exchange the Outlet Valve	142
Exchange the Purge Valve Frit or the Purge Valve	144
Replace the O-Ring on the Purge Valve	148
Remove the Pump Head Assembly	149
Maintenance of a Pump Head Without Seal Wash Option	151
Maintenance of a Pump Head with Seal Wash Option	154
Reinstall the Pump Head Assembly	158
Seal Wear-in Procedure	160
Exchange the Multi-Channel Gradient Valve (MCGV)	161
Exchange the Active Inlet Valve (AIV) or its Cartridge	164
Exchange the Seal Wash Cartridge	166
Replace Leak Handling System Parts	167
Replacing the Module Firmware	168

This chapter describes the maintenance of the module.



Introduction to Maintenance and Repair

The module is designed for easy repair. The most frequent repairs such as piston seal change and purge valve frit change can be done from the front of the module with the module in place in the system stack.

Warnings and Cautions

WARNING**Toxic, flammable and hazardous solvents, samples and reagents**

The handling of solvents, samples and reagents can hold health and safety risks.

- When working with these substances observe appropriate safety procedures (for example by wearing goggles, safety gloves and protective clothing) as described in the material handling and safety data sheet supplied by the vendor, and follow good laboratory practice.
 - The volume of substances should be reduced to the minimum required for the analysis.
 - Do not operate the instrument in an explosive atmosphere.
-

WARNING**Electrical shock**

Repair work at the module can lead to personal injuries, e.g. shock hazard, when the cover is opened.

- Do not remove the cover of the module.
 - Only certified persons are authorized to carry out repairs inside the module.
-

WARNING**Personal injury or damage to the product**

Agilent is not responsible for any damages caused, in whole or in part, by improper use of the products, unauthorized alterations, adjustments or modifications to the products, failure to comply with procedures in Agilent product user guides, or use of the products in violation of applicable laws, rules or regulations.

- Use your Agilent products only in the manner described in the Agilent product user guides.
-

CAUTION**Safety standards for external equipment**

- If you connect external equipment to the instrument, make sure that you only use accessory units tested and approved according to the safety standards appropriate for the type of external equipment.
-

Overview of Maintenance and Repair

The following pages describe maintenance (simple repairs) of the pump that can be carried out without opening the main cover.

Table 20 Simple repair procedures

Procedure	Typical Frequency	Notes
“Checking and Replacing the Solvent Filter” on page 139	If solvent filter is blocked	Gradient performance problems, intermittent pressure fluctuations
“Exchange the Passive Inlet Valve” on page 140	If internally leaking	Pressure ripple unstable, run Leak Rate Test for verification
“Exchange the Active Inlet Valve (AIV) or its Cartridge” on page 164	If internally leaking	Pressure ripple unstable, run Leak Rate Test for verification
“Exchange the Outlet Valve” on page 142	If internally leaking	Pressure ripple unstable, run Leak Rate Test for verification
“Exchange the Purge Valve Frit or the Purge Valve” on page 144	If internally leaking	Solvent dripping out of waste outlet when valve closed
“Exchange the Purge Valve Frit or the Purge Valve” on page 144	If the frit shows indication of contamination or blockage	A pressure drop of > 10 bar across the frit (at a water flow of 5 mL/min with open purge valve) indicates blockage
“Maintenance of a Pump Head Without Seal Wash Option” on page 151	If pump performance indicates seal wear	Leaks at lower pump head side, unstable retention times, pressure ripple unstable - run Leak Rate Test for verification
Exchange pistons, see “Maintenance of a Pump Head Without Seal Wash Option” on page 151	If scratched	Seal life time shorter than usual - check pistons while changing the seals

Cleaning the Module

To keep the module case clean, use a soft cloth slightly dampened with water, or a solution of water and mild detergent.

WARNING

Liquid dripping into the electronic compartment of your module can cause shock hazard and damage the module

- Do not use an excessively damp cloth during cleaning.
 - Drain all solvent lines before opening any connections in the flow path.
-

Remove and Install Doors

Parts required	p/n	Description
	5067-5746	Door Assembly Infinity 180 Right
	5067-5745	Door Assembly Infinity 180 Left

NOTE

The figures shown in this procedure exemplarily show the Infinity II Multisampler module. The principle of how to remove and/or install doors works in the same way for all Infinity II modules.

1 Press the release buttons and pull the front door out.

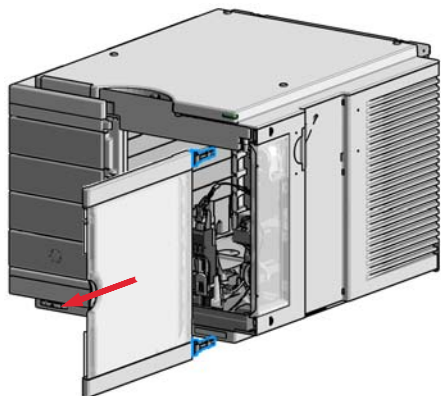
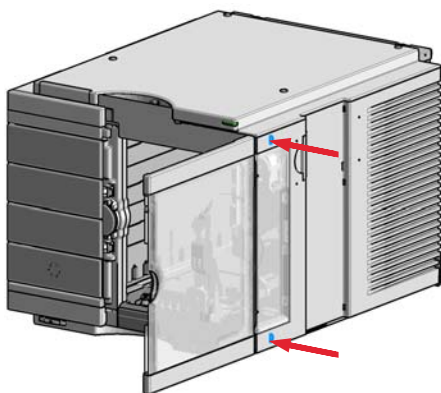

2 For the Installation of the front door. Insert the hinges into their guides and move the door in until the release buttons click into their final position.

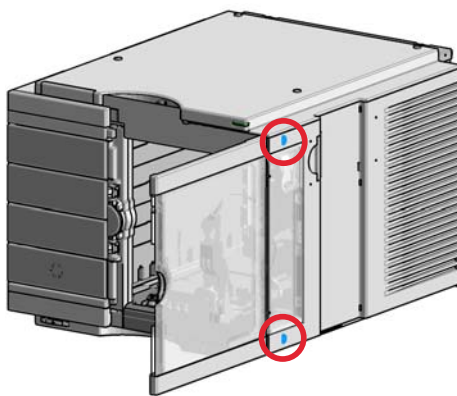
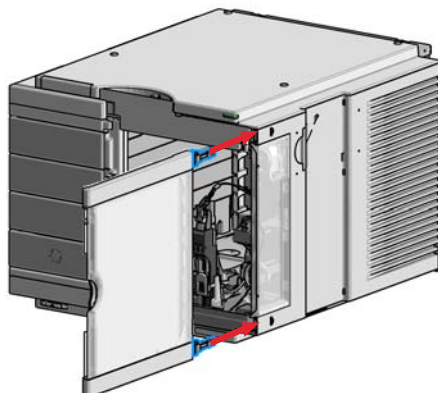

Checking and Replacing the Solvent Filter

A functional solvent filter is essential for a good pump performance and for protecting the LC system.

When If solvent filter is blocked.

Parts required	p/n	Description
	5041-2168	Solvent inlet filter, 20 µm pore size

See “[Bottle Head Assembly](#)” on page 183 for related parts.

CAUTION

Small particles can permanently block the capillaries and valves of the module.
 Damage of the module.

- Always filter solvents.
- Never use the module without solvent inlet filter.

NOTE

If the filter is in good condition the solvent will freely drip out of the solvent tube (hydrostatic pressure). If the solvent filter is partly blocked only very little solvent will drip out of the solvent tube.

- 1 Remove the solvent filter from the inlet filter adapter and replace it by a new one.

8 Maintenance

Exchange the Passive Inlet Valve

Exchange the Passive Inlet Valve

When If internally leaking (backflow)

Tools required	p/n	Description
		Wrench, 14 mm
		Pair of tweezers
	5067-5688	Torque wrench 1 – 25 Nm with 14 mm wrench

Parts required	p/n	Description
	G1312-60066	Passive inlet valve 1220/1260

Preparations

- Switch off the pump at the main power switch.
- Open the doors of the module.

1 Disconnect the solvent inlet tube from the inlet valve.

NOTE

Beware of leaking solvents due to hydrostatic pressure.

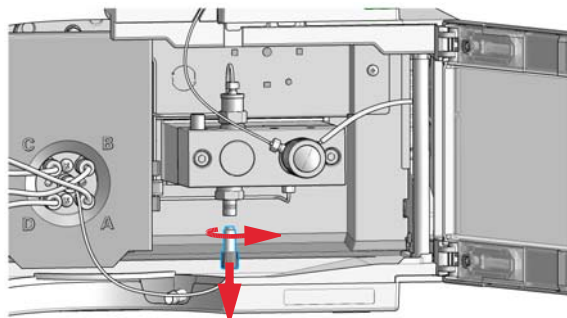

2 Using a 14 mm wrench loosen the passive inlet valve and remove the valve from the pump head.

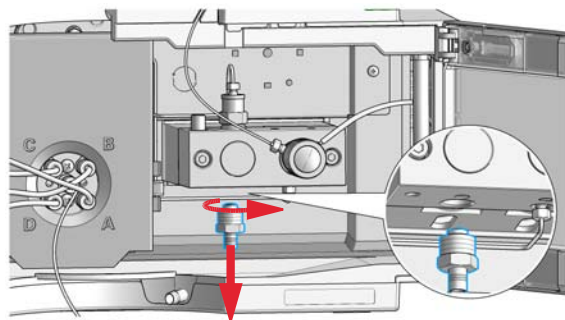

Exchange the Passive Inlet Valve

- 3** Insert the new valve into the pump head and tighten the valve using a torque wrench (approx. 10 Nm).

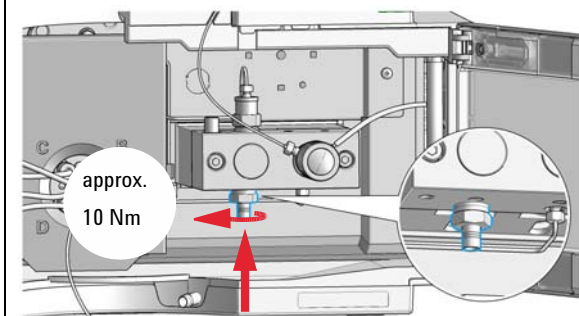

- 4** Reconnect the solvent inlet tube to the passive inlet valve.

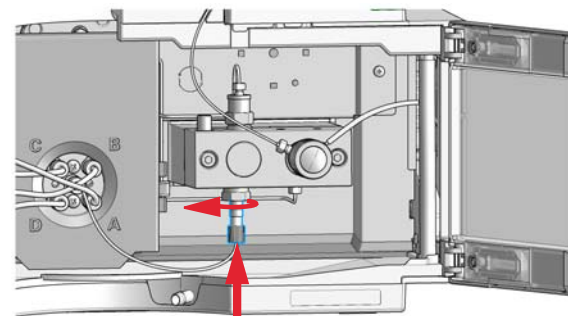

- 5** Close the doors.

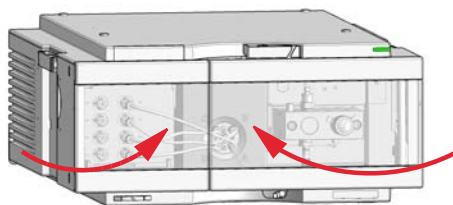

Exchange the Outlet Valve



For bio-inert modules use bio-inert parts only!

When If internally leaking

Tools required	p/n	Description
	8710-0510	Wrench open 1/4 — 5/16 inch
	8710-1924	Wrench open 14 mm
	5067-5688	Torque wrench 1 – 25 Nm with 14 mm wrench

Parts required	p/n	Description
	G1312-60067	Outlet valve 1220/1260
	G5611-60067	Outlet Valve (Bio-inert)

- Preparations**
- Switch off the pump at the main power switch.
 - Open the doors of the module.

1 Using a 1/4 inch wrench disconnect the valve capillary from the outlet valve.

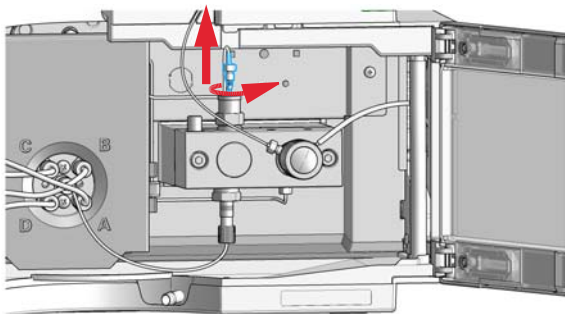

2 Using the 14 mm wrench loosen the valve and remove it from the pump body.

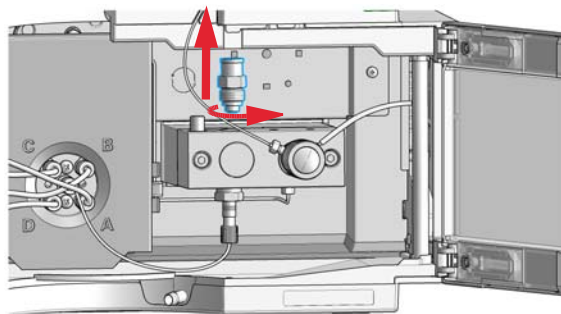

NOTE

Do not disassemble the outlet valve, as this can damage the valve.

3 Reinstall the outlet valve and tighten it using a torque wrench set to approx. 10 Nm.

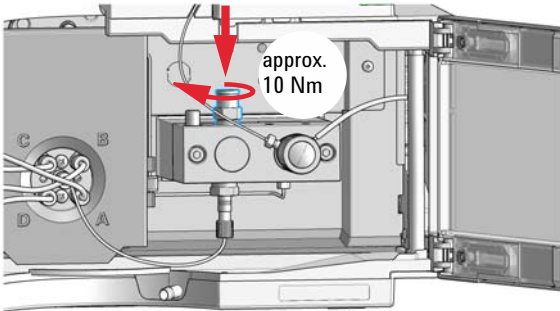

4 Reconnect the valve capillary to the outlet valve.

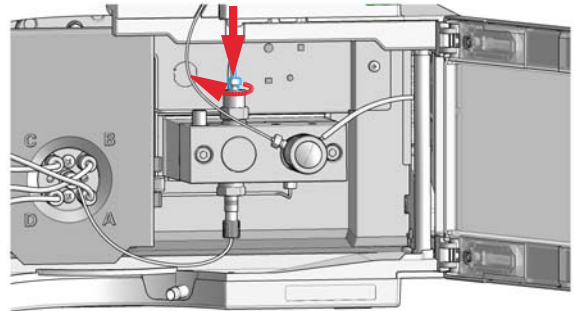

5 Close the doors.

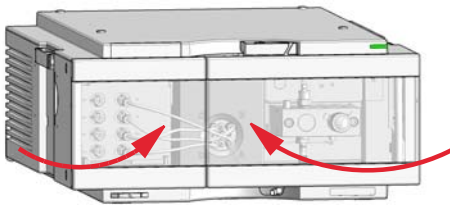

8 Maintenance

Exchange the Purge Valve Frit or the Purge Valve

Exchange the Purge Valve Frit or the Purge Valve



For bio-inert modules use bio-inert parts only!

- When**
- Frit – when piston seals are exchanged or when contaminated or blocked (pressure drop of > 10 bar across the frit at a flow rate of 5 mL/min of water with purge valve opened)
 - Purge valve – if internally leaking

Tools required	p/n	Description
	8710-0510	Wrench open 1/4 — 5/16 inch
	8710-1924	Wrench open 14 mm
		Pair of tweezers
OR		Toothpick

Parts required	#	p/n	Description
	1	G7111-60061	Purge valve for G7110B, G7111A, and G7111B
	1	G5611-60064	Purge valve for G5654A
	1	01018-22707	PTFE frits (pack of 5)
	1	5067-4728	Seal cap (OPTIONAL)

- Preparations**
- Switch off the pump at the main power switch.
 - Open the doors of the module.
 - Use an optional solvent shutoff valve or lift up solvent filters in solvent reservoirs for avoiding leakages.

Exchange the Purge Valve Frit or the Purge Valve

- 1 Using a 1/4 inch wrench disconnect the pump outlet capillary from the purge valve. Disconnect the waste tube.

NOTE

Beware of leaking solvents due to hydrostatic pressure.

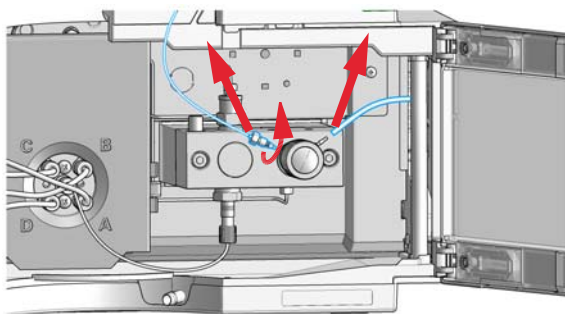

- 2 Using the 14 mm wrench unscrew the purge valve and remove it.

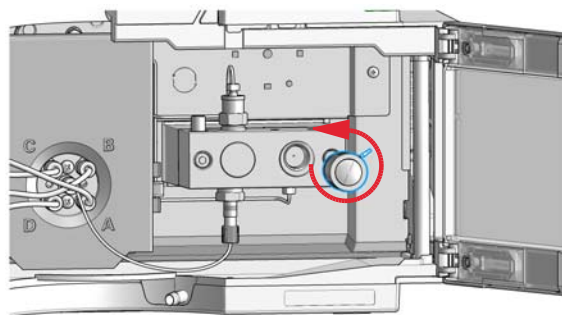

- 3 Remove the seal cap from the purge valve.

Seal cap

Frit

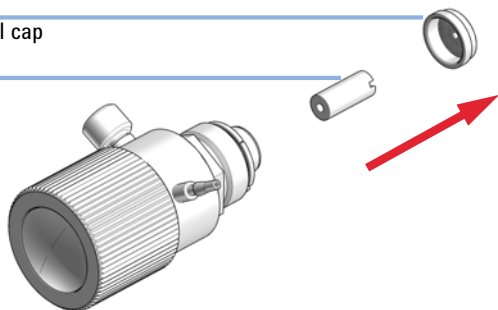

- 4 Using a pair of tweezers or a toothpick remove the frit.

8 Maintenance

Exchange the Purge Valve Frit or the Purge Valve

- 5 Place a new frit into the purge valve with the orientation of the frit as shown below (slit in frit points to the front).

Seal cap

Frit

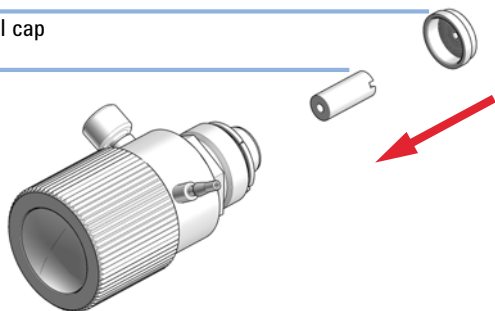

- 6 Reinstall the seal cap including the gold seal.

NOTE

Before reinstallation always check the gold seal in the seal cap. A deformed seal cap should be exchanged.

CAUTION

Damage to the purge valve

- Do not lift the pump using the purge valve as a handle, it might get leaky.
- Do not try to turn the purge valve into the correct position when already fixed to the pump. The rubber o-ring might break.
- Anticipate the correct position of the connections before tightening the valve.

- 7 Insert the purge valve into the pump head and fix it with a 14 mm wrench.

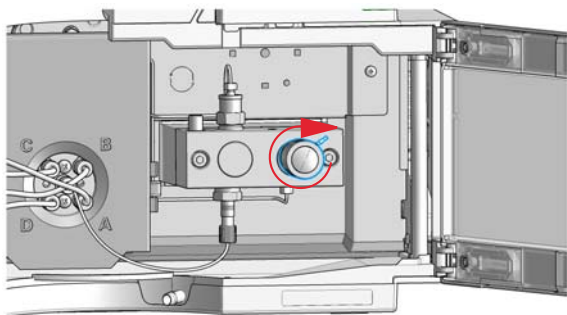

- 8 Reconnect the outlet capillary and the waste tubing.

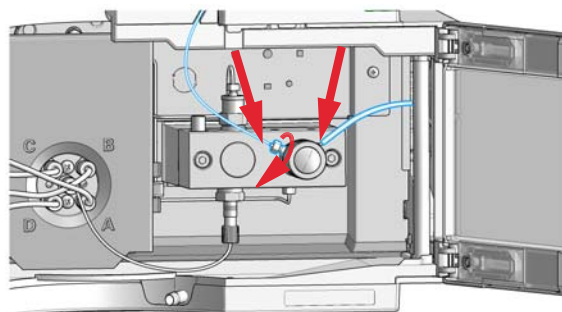

Exchange the Purge Valve Frit or the Purge Valve

9 Close the doors.

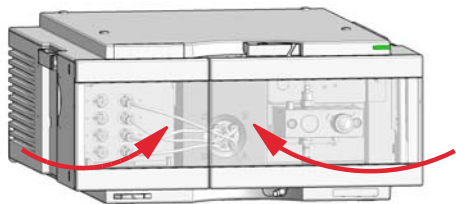

8 Maintenance

Replace the O-Ring on the Purge Valve

Replace the O-Ring on the Purge Valve

When If the original o-ring is damaged and needs to be replaced

Tools required	p/n	Description
	8710-0510	Wrench open 1/4 — 5/16 inch
	8710-1924	Wrench open 14 mm
		Pair of tweezers
OR		Toothpick

Parts required	#	p/n	Description
	1	5067-6595	1260 PV O-ring FKM 5/pack
	1	01018-22707	PTFE frits (pack of 5) (OPTIONAL)
	1	5067-4728	Seal cap (OPTIONAL)

Preparations

- Switch off pump at the main power switch.
- Open the doors of the module.
- Use an optional solvent shutoff valve or lift up solvent filters in solvent reservoirs for avoiding leakages.
- Remove the purge valve from the pump head.

- 1 Remove the old o-ring from the purge valve.
- 2 Clean the purge valve parts.
- 3 Place the new o-ring on the Screw Purge Valve.
- 4 Place the screw with o-ring on the Purge Valve Body.
- 5 Place the mounting ring on the screw.
- 6 Push the screw up and guide the o-ring into the gab.
- 7 Install the purge valve to the pump, make sure that you do not turn the Purge Valve Body when the screw is fixed to the pump. The o-ring will take damage.

Remove the Pump Head Assembly

- When**
- Exchanging the seals
 - Exchanging the pistons
 - Exchanging seals of the seal wash function

Tools required	p/n	Description
	8710-0510	Wrench open 1/4 — 5/16 inch
	8710-2392	Hexagonal key, 4.0 mm, 15 cm long, T-handle

- Preparations**
- Switch off the pump at the main power switch and unplug the power cable.
 - Use an optional solvent shutoff valve or lift up solvent filters in solvent reservoirs for avoiding leakages.
 - Open the doors of the module.
 - If an active inlet valve is installed, disconnect the active inlet valve cable.

CAUTION

Damage of the pump drive

Starting the pump when the pump head is removed may damage the pump drive.

→ Never start the pump when the pump head is removed.

- 1** Using a 1/4 inch wrench disconnect the valve capillary from the outlet valve.

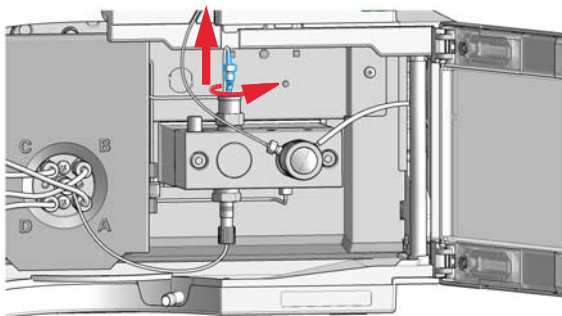

- 2** Disconnect the solvent inlet tube from the inlet valve.

NOTE

Beware of leaking solvents due to hydrostatic pressure.

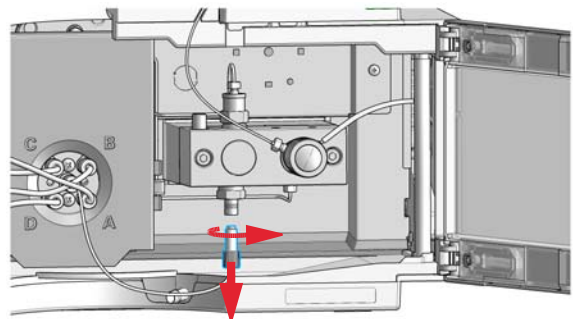

8 Maintenance

Remove the Pump Head Assembly

- 3** Using a 1/4 inch wrench disconnect the pump outlet capillary from the purge valve. Disconnect the waste tube.

NOTE

Beware of leaking solvents due to hydrostatic pressure.

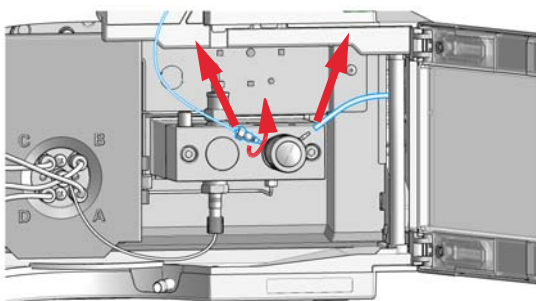

- 4** If applicable, remove tubings from the seal wash support rings.

- 5** Remove the capillary at the bottom of the pump head.

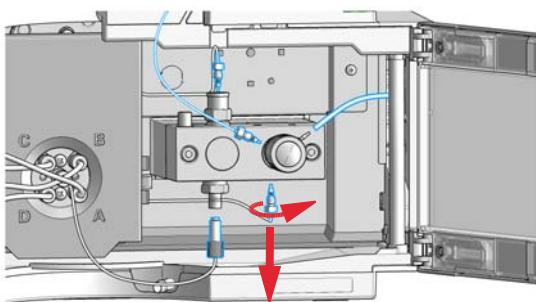

- 6** Using a 4 mm hexagonal key, stepwise loosen the two pump head screws.

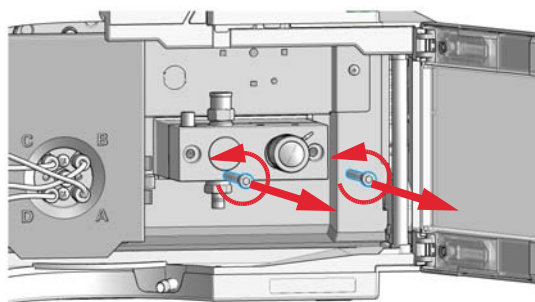

- 7** Remove the pump head from the pump drive.

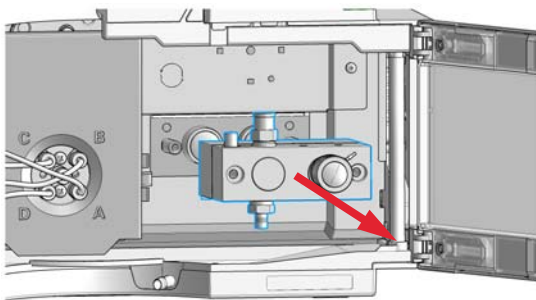

Maintenance of a Pump Head Without Seal Wash Option

When In case of maintenance or pump head internal leaks.

Tools required

Description

Wrench 1/4 inch

Hexagonal key, 4 mm

Parts required	#	p/n	Description
	1	01018-23702	Insert tool
	1	5063-6589	Piston seal PTFE, carbon filled, black (pack of 2), default
OR	1	0905-1420	PE seals (pack of 2)
	1	5063-6586	Sapphire piston
	1	5061-5896	Abrasive paper

Preparations

- Switch off the pump at the main power switch.
- Open the doors of the module.
- Remove the Pump Head Assembly.

1 Place the pump head on a flat surface. Loosen the lock screw (two turns).

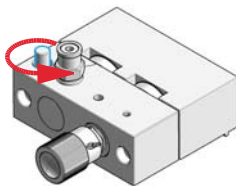

2 While holding the lower half of the assembly (piston housing), carefully pull the pump housing away from the piston housing.

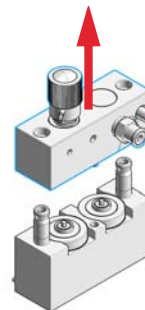

8 Maintenance

Maintenance of a Pump Head Without Seal Wash Option

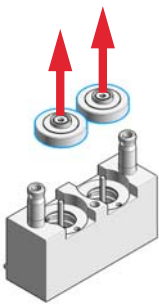
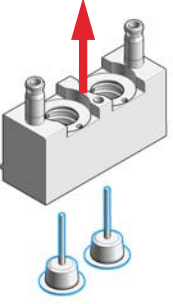
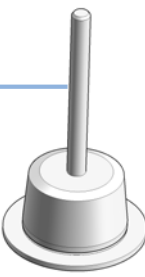
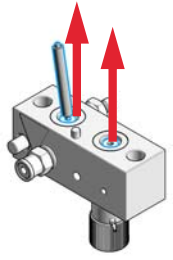
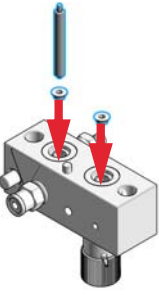
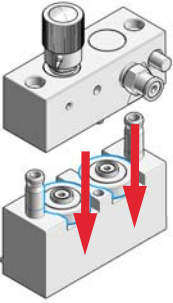
<p>3 Remove the support rings from the piston housing.</p> 	<p>4 Lift the housing away from the pistons.</p> 
<p>5 Check the piston surface and remove any deposits or layers: clean the piston surface with abrasive paper and rinse with 2-propanol. Replace piston if scratched.</p> <p>Piston Surface</p> 	<p>6 Using the steel side of the insert tool, carefully remove the seal from the pump housing.</p> 
<p>7 Using the plastic side of the insert tool, insert new seals into the pump head.</p> 	<p>8 Place the support rings on the piston housing. Note the correct position of the pins.</p> 

Maintenance of a Pump Head Without Seal Wash Option

9 Place the pump housing onto the piston housing.

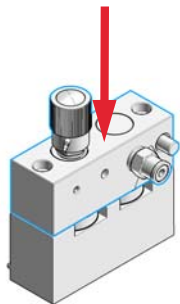

10 Insert the pistons and carefully press them into the seals.

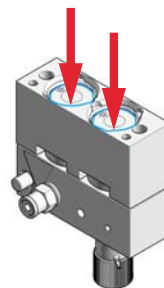

11 Tighten the lock screw.

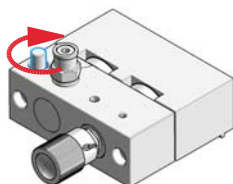

12 Install the pump head, see [“Reinstall the Pump Head Assembly”](#) on page 158.

8 Maintenance

Maintenance of a Pump Head with Seal Wash Option

Maintenance of a Pump Head with Seal Wash Option



For bio-inert modules use bio-inert parts only!

When In case of maintenance or pump head internal leaks.

Tools required

Description
Wrench 1/4 inch
Hexagonal key, 4 mm

Parts required	#	p/n	Description
	1	01018-23702	Insert tool
	1	0905-1175	Wash seal (PTFE)
OR	1	0905-1718	Wash Seal PE
	1	5062-2484	Gasket, seal wash (pack of 6)
	1	5063-6589	Piston seal PTFE, carbon filled, black (pack of 2), default
	1	0905-1420	PE seals (pack of 2)
	1	5063-6586	Sapphire piston
	1	5061-5896	Abrasive paper

Preparations

- Switch off the pump at the main power switch.
- Open the doors of the module.
- Use an optional solvent shutoff valve or lift up solvent filters for avoiding leakages.
- Remove the Pump Head Assembly.
- Remove the wash solvent tubings from the support ring inlet and outlet.

Maintenance of a Pump Head with Seal Wash Option

1 Place the pump head on a flat surface. Loosen the lock screw (two turns).

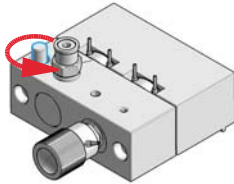

2 While holding the lower half of the assembly (piston housing), carefully pull the pump housing away from the piston housing.

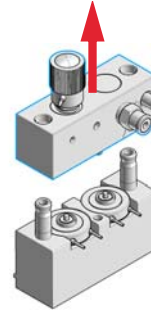

3 Remove the seal holder and the seal wash support rings from the piston housing.

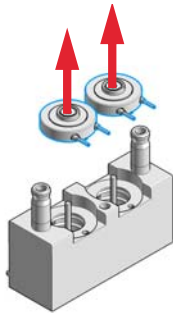

4 Remove the seal holder from the support ring assembly.

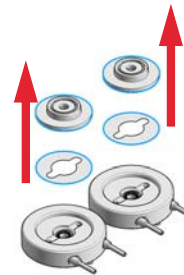

5 Lift the housing away from the pistons.

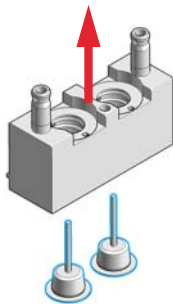

6 Check the piston surface and remove any deposits or layers: clean the piston surface with abrasive paper and rinse with 2-propanol. Replace piston if scratched.

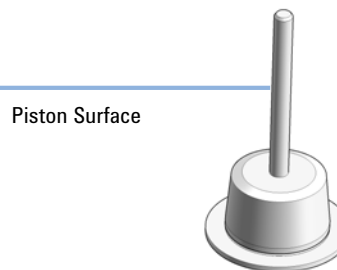

8 Maintenance

Maintenance of a Pump Head with Seal Wash Option

- 7** Using the steel side of the insert tool, carefully remove the seal from the pump housing.

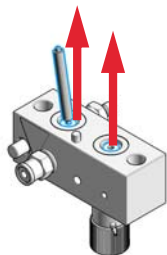

- 8** Using the plastic side of the insert tool, insert new seals into the pump head.

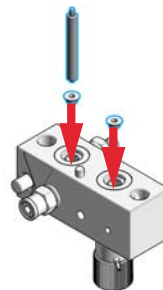

- 9** Using the steel side of the insert tool, remove the seal wash gasket and the wash seal from the support ring.

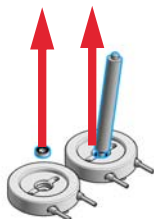

- 10** Using the plastic side of the insert tool, press the new wash seal (spring pointing upwards) into the recess of the support ring.

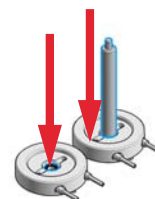

- 11** Place a seal wash gasket in the recess of the support ring. Use a matching orientation of gasket and support ring. Put the seal holder on top of the gasket.

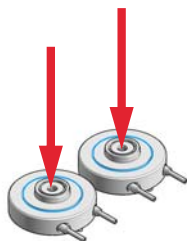

- 12** Place the support rings on the piston housing. Note the correct position of the pins on the support ring.

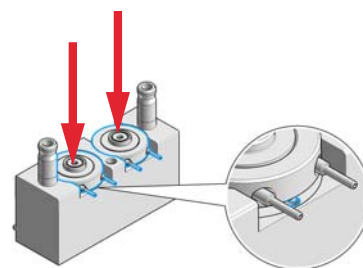

13 Place the pump housing onto the piston housing.

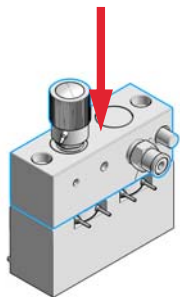

14 Insert the pistons and carefully press them into the seals.

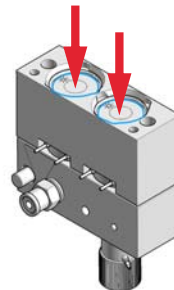

15 Tighten the lock screw.

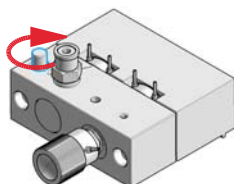

16 Install the pump head, see [“Reinstall the Pump Head Assembly”](#) on page 158.

8 Maintenance

Reinstall the Pump Head Assembly

Reinstall the Pump Head Assembly

When When reassembling the pump

Tools required

p/n	Description
8710-2392	Hex key 4 mm15 cm long T-handle

Parts required

#	p/n	Description
1	79846-65501	Pump head grease

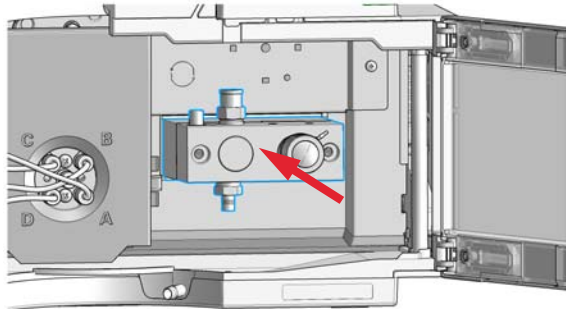
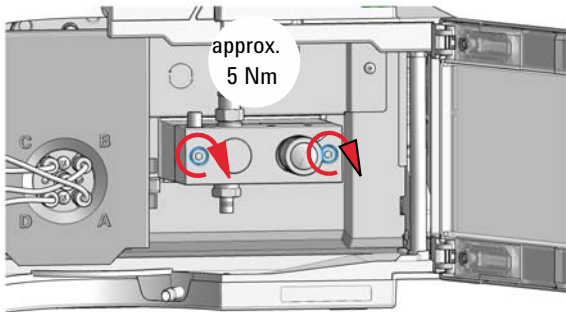
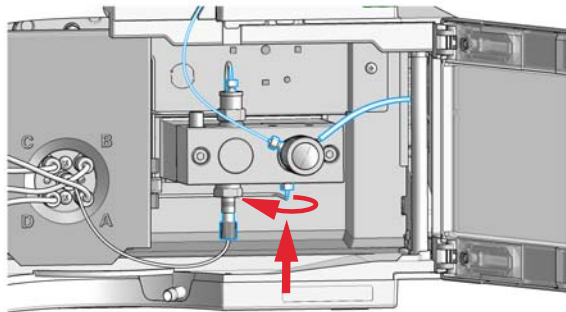
<p>1 If needed, apply a small amount of grease on the back of the screws. Normally, the grease added during manufacturing is sufficient for a long time.</p>	<p>2 Slide the pump head assembly onto the pump drive.</p> 
<p>3 Insert the pump head screws and tighten them stepwise with increasing torque (approx. 5 Nm) with a 4 mm hexagonal key.</p> 	<p>4 Install the capillary at the bottom of the pump head.</p> 

Reinstall the Pump Head Assembly

5 Reconnect the valve capillary to the outlet valve.

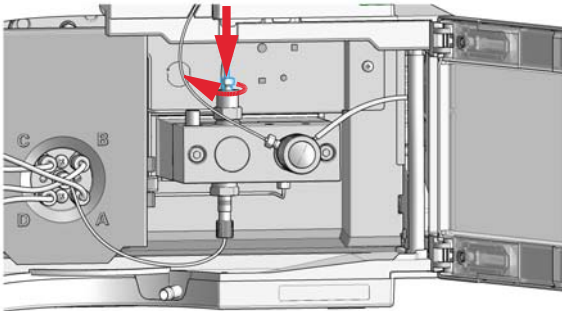

6 Reconnect the solvent inlet tube to the passive inlet valve.

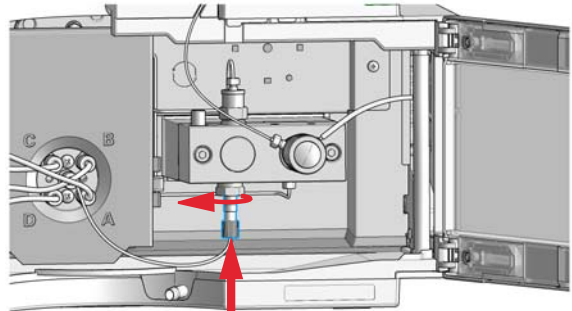

7 Reconnect the outlet capillary and the waste tubing.

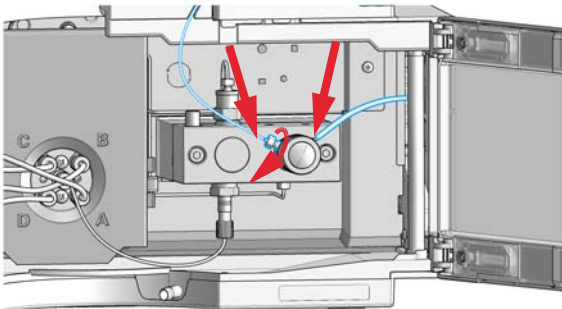

8 If installed, reconnect the active inlet valve cable to its connector.

9 Close the doors.

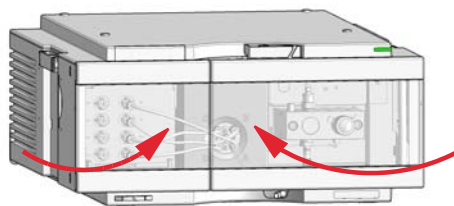
**Next Steps:**

10 If a standard seal has been installed, run the seal wear-in procedure, which includes a replacement of the purge valve frit ("[Seal Wear-in Procedure](#)" on page 160).

11 For the normal phase seal, the purge valve frit should be replaced, see "[Exchange the Purge Valve Frit or the Purge Valve](#)" on page 144.

Seal Wear-in Procedure

Parts required	p/n	Description
	0100-1847	Adapter AIV to solvent inlet tubes
	5022-2159	Restriction capillary

NOTE

Before replacing your solvent by isopropanol or replacing isopropanol by your solvent, consider solvent miscibility. For example, do not directly switch from buffers to isopropanol and vice versa.

- 1 Place a bottle with 100 mL of isopropanol in the solvent cabinet and put a tubing (including bottle head assembly) into the bottle.
- 2 If an active inlet valve is installed, screw the PEEK adapter 1/4-28 to 10-32 (0100-1847) to the AIV and connect the inlet tube from the bottle head directly to it.
- 3 Connect the Restriction capillary (5022-2159) to the purge valve. Connect its other end to a waste container.
- 4 Open the purge valve and purge the system for 5 min with isopropanol at a flow rate of 2 mL/min.
- 5 Close the purge valve and set the flow to a rate adequate to achieve a pressure of 350 bar. Pump 15 min at this pressure to wear in the seals. The pressure can be monitored using your instrument control software or tool.
- 6 Turn OFF the pump, slowly open the purge valve to release the pressure from the system, disconnect the restriction capillary and reinstall the bottle with the solvent for your application.
- 7 Rinse your system with the solvent used for your next application.
- 8 Replace the purge valve frit, see [“Exchange the Purge Valve Frit or the Purge Valve”](#) on page 144.

Exchange the Multi-Channel Gradient Valve (MCGV)



For bio-inert modules use bio-inert parts only!

(Quaternary pumps only)

Tools required	p/n	Description	
	8710-0899	Screwdriver, Pozidriv #1	
Parts required	#	p/n	Description
	1	G1311-67701	Multi channel gradient valve (MCGV)
OR	1	G5611-67701	Multi-Channel Gradient Valve (MCGV) (Bio-inert)
Preparations	<ul style="list-style-type: none"> • Switch off the pump at the main power switch. • Open the doors of the module. • Use an optional solvent shutoff valve or lift up solvent filters in solvent reservoirs for avoiding leakages. 		

NOTE

The life time of the multi-channel gradient valve can be increased by regularly flushing the valve, especially when using buffers. If using buffers, flush all channels of the valve with water to prevent precipitation of the buffer, otherwise salt crystals could drop into an unused channel and form plugs that may cause leaks of that channel. Such leaks will interfere with the general performance of the valve. When using buffers in combination with organic solvents, it is recommended to connect the aqueous solutions/buffers to one of the bottom ports (A and D) and the organic solvent to one of the upper gradient valve ports. It is best to have the organic channel directly above the buffer channel (e.g., A - buffer, B - organic solvent).

8 Maintenance

Exchange the Multi-Channel Gradient Valve (MCGV)

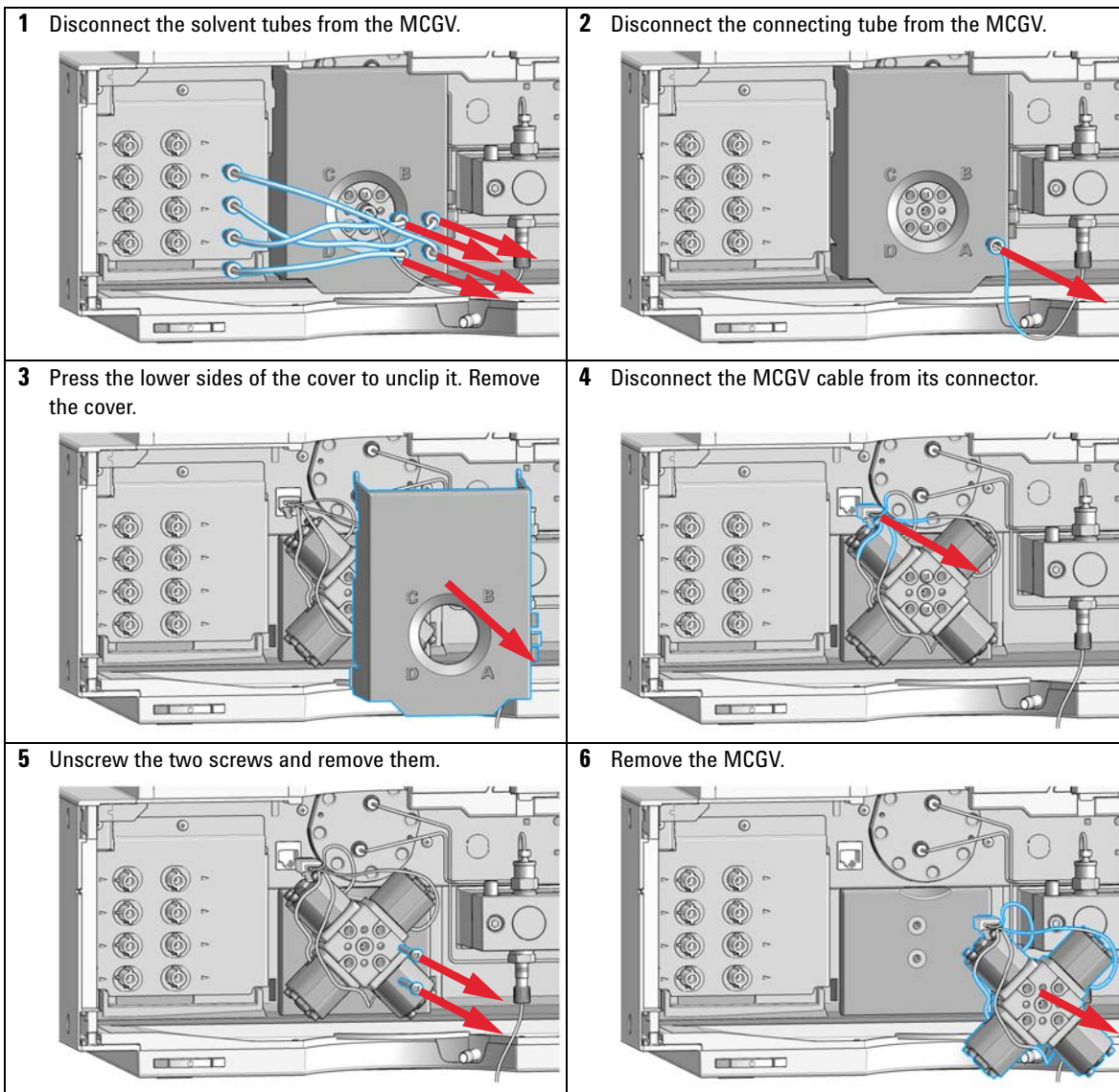

Exchange the Multi-Channel Gradient Valve (MCGV)

- 7** Place the new MCGV into position. Make sure that channel A of the MCGV is put at the bottom-right position.

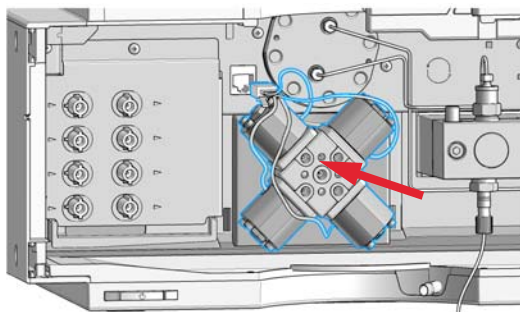

- 8** Tighten the two screws

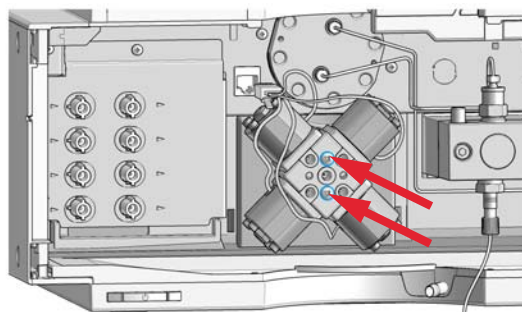

- 9** Connect the cable to its connector.

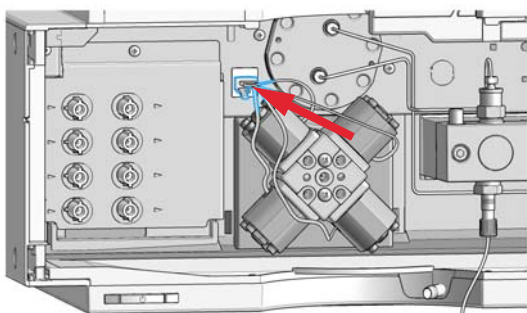

- 10** Install the MCGV cover.

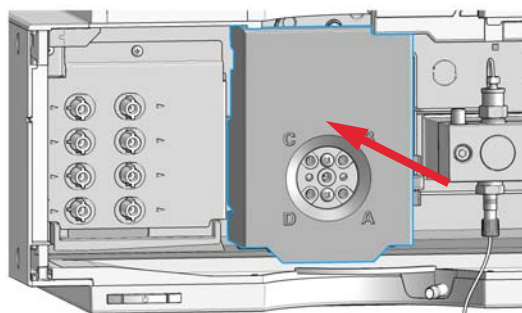

- 11** Reconnect the tube from the inlet valve to the middle position of the MCGV.

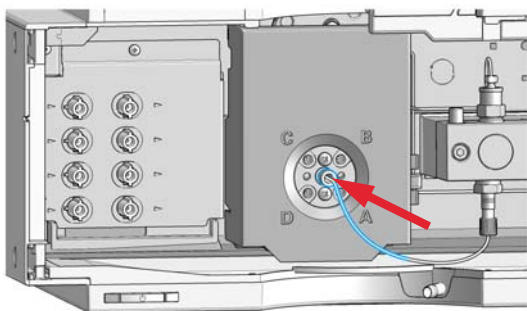

- 12** Connect solvent tubes for channels A-D from the MCGV to the degasser outlets.

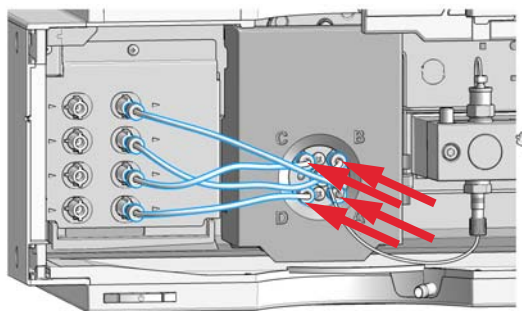

8 Maintenance

Exchange the Active Inlet Valve (AIV) or its Cartridge

Exchange the Active Inlet Valve (AIV) or its Cartridge



For bio-inert modules use bio-inert parts only!

When If internally leaking (backflow)

Tools required

Description

Wrench, 14 mm

Pair of tweezers

Parts required

p/n	Description
G5699A	Active Inlet Valve Upgrade Kit
G1312-60025	Active inlet valve body, without cartridge
G1312-60020	Cartridge for active inlet valve 600 bar
G1311-67304	Connecting tube
G1311-61601	Active Inlet Valve Cable Assembly
0100-2298	Adapter, PEEK int. 1/4-28 to ext. 10-32
G5611-60025	Active Inlet Valve (AIV, Bio-inert), without cartridge
G5611-60020	Cartridge for AIV (Bio-inert)

Preparations

- Switch off pump at the main power switch and unplug the power cable.
- Use an optional solvent shutoff valve or lift up solvent filters in solvent reservoirs for avoiding leakages.

- 1 Unplug the active inlet valve cable from the connector.
- 2 Disconnect the solvent inlet tube from the inlet valve (be aware that solvent may leak out of the tube due to hydrostatic flow).
- 3 Unscrew the adapter from the active inlet valve.

Exchange the Active Inlet Valve (AIV) or its Cartridge

- Using a 14 mm wrench loosen the active inlet valve and remove the valve from the pump head.

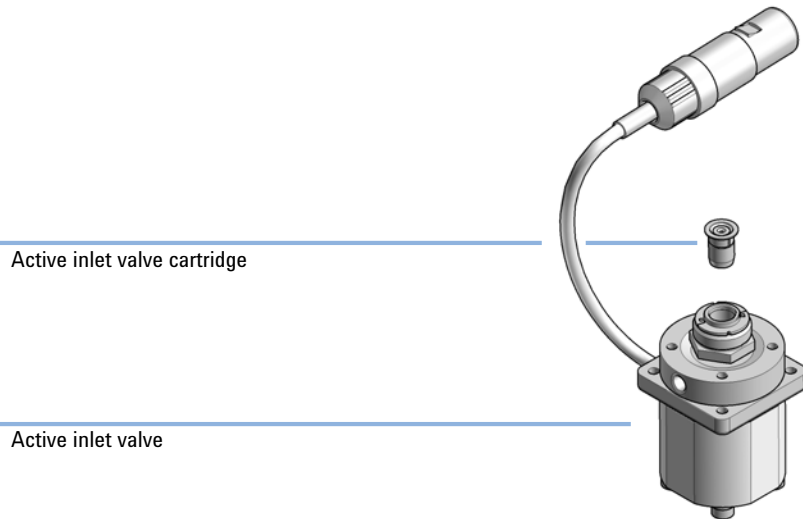

- Using a pair of tweezers remove the valve cartridge from the actuator assembly.
- Before inserting the new valve cartridge clean the area in the actuator assembly. Flush the cartridge area thoroughly with alcohol.
- Insert a new cartridge into the actuator assembly (make sure the valve cartridge is completely inserted into the actuator assembly).
- Insert the new valve into the pump head. Using the 14 mm wrench turn the nut until it is hand tight.
- Position the valve such that the solvent inlet tube connection points towards the front.
- Using the 14 mm wrench tighten the nut by turning the valve into its final position (not more than a quarter turn).
- Reconnect the adapter at the active inlet valve.
- Reconnect the solvent inlet tube to the adapter. Reconnect the active inlet valve cable to the connector in the Z-panel.
- Purge the system with 30 mL of solvent in order to achieve a low pressure ripple.

8 Maintenance

Exchange the Seal Wash Cartridge

Exchange the Seal Wash Cartridge

Parts required	p/n	Description
	5065-4445	Peristaltic pump with Pharmed tubing

- Preparations**
- Switch off pump at the main power switch.
 - Open the doors.

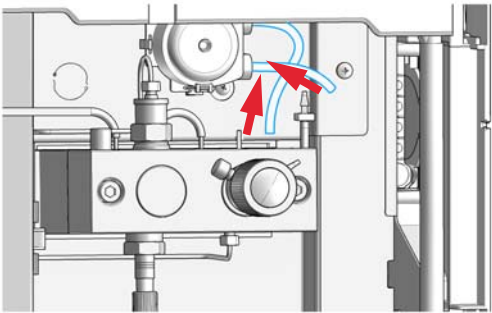
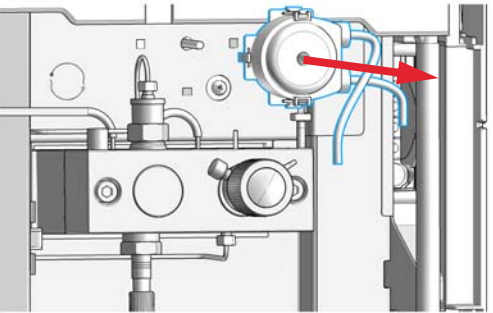
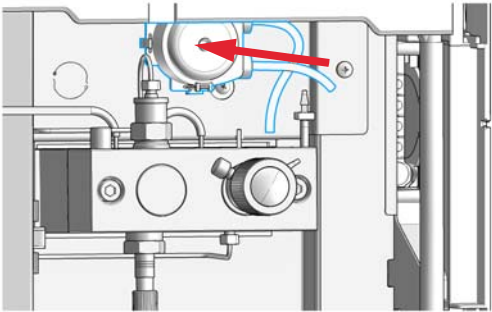
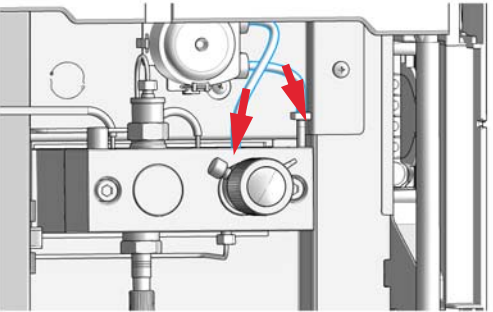
<p>1 Remove the wash solvent tubings from the support ring outlet and from the adapter leading to the waste bottle.</p> 	<p>2 Unclip the peristaltic pump cartridge from the module housing and remove it.</p> 
<p>3 Put the new peristaltic pump cartridge onto the rod of the pump motor and push the plastic clips into the module housing.</p> 	<p>4 Connect the peristaltic pump tubes to the support rings outlet and to the adapter leading to the waste bottle.</p> 

Replace Leak Handling System Parts

Parts required	p/n	Description
	5043-0856	Leak Adapter
	5063-6527	Tubing assembly, i.d. 6 mm, o.d. 9 mm, 1.2 m (to waste) approximately 85 mm required

- 1 Open the doors.
- 2 Press the Leak Adapter down and remove it together with the tubing.
- 3 Install the Leak Adapter by pressing it into the Main Cover.
- 4 Insert the Tubing (approximately 85 mm required for replacement) between Leak Adapter outlet and Leak Panel.
- 5 Close the doors.

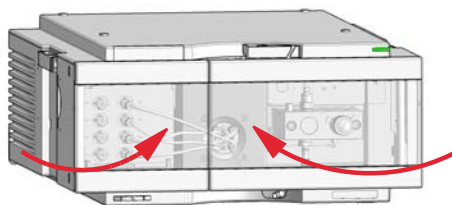

Replacing the Module Firmware

When

The installation of newer firmware might be necessary

- if a newer version solves problems of older versions or
- to keep all systems on the same (validated) revision.

The installation of older firmware might be necessary

- to keep all systems on the same (validated) revision or
- if a new module with newer firmware is added to a system or
- if third party control software requires a special version.

Tools required

Description

Agilent Lab Advisor software

OR

Instant Pilot G4208A
(only if supported by module)

Parts required

#	Description
1	Firmware, tools and documentation from Agilent web site

Preparations

Read update documentation provided with the Firmware Update Tool.

To upgrade/downgrade the module's firmware carry out the following steps:

- 1 Download the required module firmware, the latest FW Update Tool and the documentation from the Agilent web.
<http://www.agilent.com/en-us/firmwareDownload?whid=69761>
- 2 For loading the firmware into the module follow the instructions in the documentation.

Module Specific Information

There is no specific information for this module.

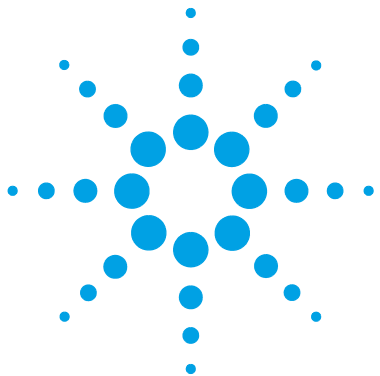

9 Parts for Maintenance

Accessory Kits	170
Pump Head Assembly Without Seal Wash	172
Pump Head Assembly with Seal Wash	174
Outlet Valve	176
Purge Valve Assembly	177
Active Inlet Valve Assembly	178
1260 Infinity II Max Uptime Kit	179
1260 Infinity II Low Dispersion Kit MCT	180
HPLC System Tool Kit	181
Solvent Cabinet	182
Bottle Head Assembly	183
Hydraulic Path of the Quaternary Pump	184
Hydraulic Path of the Isocratic Pump	186
Leak Parts	188

This chapter provides information on parts for maintenance.



Accessory Kits

Accessory Kit G7111-68755

The Accessory Kit (G7111-68755) contains the following items:

#	p/n	Description
2	5043-1013	Tubing Clip
1	5181-1519	CAN cable, Agilent module to module, 1 m
1	5500-1246	Capillary ST 0.17 mm x 500 mm SI/SI
1	5500-1217	Capillary ST 0.17 mm x 900 mm SI/SX ps-ps
3	5063-6527	Tubing assembly, i.d. 6 mm, o.d. 9 mm, 1.2 m (to waste)
1	G1311-90107	Algae note
3	5500-1169	Y Tube Connector ID6.4
3	5500-1155	Tube Connector, 90 degree, ID 6.4
1	5043-1372	Tubing Connector Leak 3-1
2	5043-1373	Tubing Connector Leak Cap

Accessory Kit G5654-68755



For bio-inert modules use bio-inert parts only!

The Accessory Kit (G5654-68755) contains the following items:

#	p/n	Description
2	5043-1013	Tubing Clip
1	5181-1519	CAN cable, Agilent module to module, 1 m
1	G5611-60502	Capillary 900 x 0.17 mm, titanium (Bio-inert)
1	5500-1264	Capillary Ti 0.17 mm x 500 mm SL/SLV
3	5063-6527	Tubing assembly, i.d. 6 mm, o.d. 9 mm, 1.2 m (to waste)
1	G1311-90107	Algae note
3	5500-1155	Tube Connector, 90 degree, ID 6.4
2	5043-1373	Tubing Connector Leak Cap
1	5043-1372	Tubing Connector Leak 3-1
3	5500-1169	Y Tube Connector ID6.4

Pump Head Assembly Without Seal Wash

Item	p/n	Description
	G1312-60056	Pump Head 1200 SL without Seal Wash
1	5063-6586	Sapphire piston
2	G1311-60002	Piston housing
3	5067-1560	Support Ring SL, no seal wash
4	5062-2484	Gasket, seal wash (pack of 6)
5	5042-8952	Seal holder
6	5063-6589	Piston seal PTFE, carbon filled, black (pack of 2), default
OR	0905-1420	PE seals (pack of 2)
7	G1311-25200	Pump chamber housing
8	G1312-60066	Passive inlet valve 1220/1260
	G1312-60025	Active inlet valve body, without cartridge (OPTIONAL)
	G1312-60020	Cartridge for active inlet valve 600 bar (OPTIONAL) for G7110B, G7111B, and G5654A (OPTIONAL)
	5062-8562	Active Inlet Valve Cartridge (400 bar) (OPTIONAL) for G7111A (OPTIONAL)
9	G1312-60067	Outlet valve 1220/1260
10	5042-1303	Lock screw
11	G7111-60061	Purge valve for G7110B, G7111A, and G7111B
12	0515-2118	Pump head screw (M5, 60 mm)

The Pump Head 1200 SL without Seal Wash (G1312-60056) includes items 1-7, 10 and 12.

For piston seals, see [“Choosing the Right Pump Seals”](#) on page 87.

Pump Head Assembly Without Seal Wash

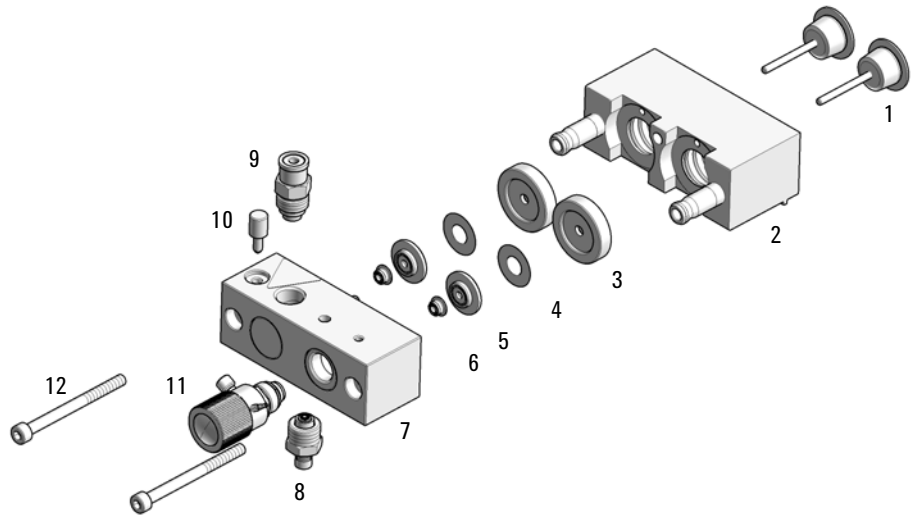

Figure 12 Pump head assembly without seal wash option

Pump Head Assembly with Seal Wash



For bio-inert modules use bio-inert parts only!

Item	p/n	Description
	G1312-60045	Pump head assembly with seal wash
OR	G5611-60165	Pump Head with Seal Wash Function (Bio-inert)
	1 5063-6586	Sapphire piston
	2 G1311-60002	Piston housing
	3 01018-60027	Support ring seal wash
	4 0905-1175	Wash seal (PTFE)
OR	0905-1718	Wash Seal PE
OR	0905-1731	Wash Seal PTFE for Bio-inert Pump 600 bar
	5 5062-2484	Gasket, seal wash (pack of 6)
	6 5042-8952	Seal holder
	7 5063-6589	Piston seal PTFE, carbon filled, black (pack of 2), default
OR	0905-1420	PE seals (pack of 2)
OR	G5611-21503	Piston Seal PTFE (Bio-inert)
	8 G1311-25200	Pump chamber housing
	9 G1312-60066	Passive inlet valve 1220/1260
	G1312-60025	Active inlet valve body, without cartridge (OPTIONAL)
	G5611-60025	Active Inlet Valve (AIV, Bio-inert), without cartridge
	G1312-60020	Cartridge for active inlet valve 600 bar (OPTIONAL) for G7110B, and G7111B (OPTIONAL)
	5062-8562	Active Inlet Valve Cartridge (400 bar) (OPTIONAL) for G7111A (OPTIONAL)
	G5611-60020	Cartridge for AIV (Bio-inert)
	10 5042-1303	Lock screw

Item	p/n	Description
11	G1312-60067	Outlet valve 1220/1260
OR	G5611-60067	Outlet Valve (Bio-inert)
12	G7111-60061	Purge valve for G7110B, G7111A, and G7111B
	G5611-60064	Purge valve for G5654A
13	0515-2118	Pump head screw (M5, 60 mm)
14	5065-4445	Peristaltic pump with Pharmed tubing
15	G1311-60161	1220/1260 Seal Wash Pump Assembly see note below
	G1398A	Active Seal Wash Option Upgrade (includes service)
	G1398-60000	Active Seal Wash Option Kit
	5065-9978	Tubing, 1 mm i.d., 3 mm o.d., silicone, 5 m for seal wash option
	01018-23702	Insert tool

The Pump head assembly with seal wash (G1312-60045) includes items 1-8, 11 and 13.

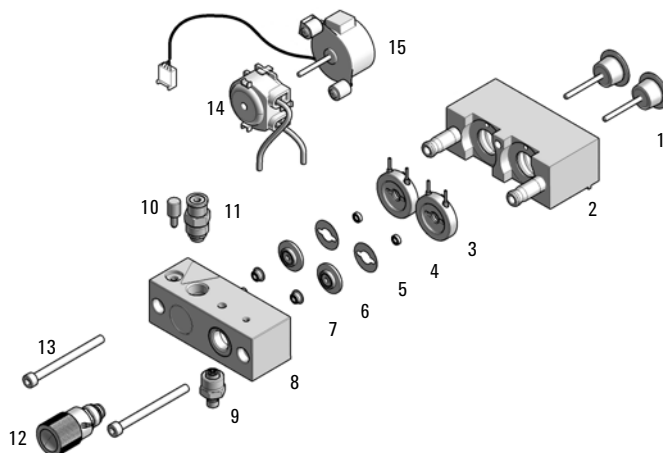
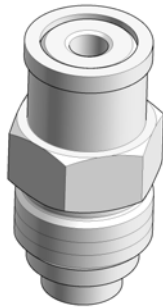

Figure 13 Pump Head with Seal Wash Option

Outlet Valve

p/n	Description
G1312-60067	Outlet valve 1220/1260
G5611-60067	Outlet Valve (Bio-inert)



Purge Valve Assembly



For bio-inert modules use bio-inert parts only!

Item	p/n	Description
1	G5611-60064	Purge valve for G5654A
1	G7111-60061	Purge valve for G7110B, G7111A, and G7111B
2	01018-22707	PTFE frits (pack of 5)
3	5067-4728	Seal cap

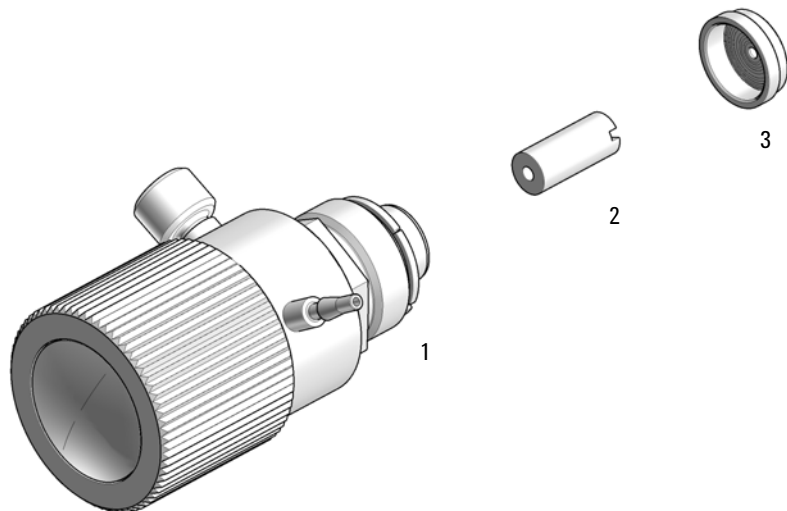

Figure 14 Purge Valve Assembly

Active Inlet Valve Assembly



For bio-inert modules use bio-inert parts only!

Item	p/n	Description
	G5699A	Active Inlet Valve Upgrade Kit includes service and the parts listed below
1	G1312-60025	Active inlet valve body, without cartridge
OR	G5611-60025	Active Inlet Valve (AIV, Bio-inert), without cartridge
OR 2	G1312-60020	Cartridge for active inlet valve 600 bar
OR	5062-8562	Active Inlet Valve Cartridge (400 bar)
OR	G5611-60020	Cartridge for AIV (Bio-inert)
	G1311-67304	Connecting tube (needed for quaternary pump only)
	0100-2298	Adapter, PEEK int. 1/4-28 to ext. 10-32 (needed for isocratic pump only)

Active inlet valve cartridge

Active inlet valve

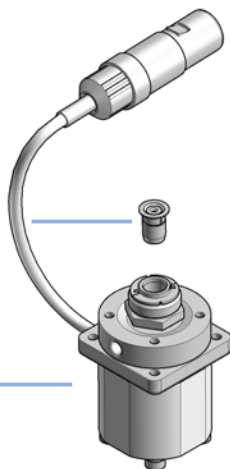

1260 Infinity II Max Uptime Kit

This kit will be sold optionally with the pump and is not essential for operation. You can reorder the individual parts.

#	p/n	Description
1	01018-22707	PTFE frits (pack of 5)
1	0890-1763	Capillary PK 0.18 mm x 1.5 m
3	5022-2184	Union, stand LD flow, no fitting
2	5041-2168	Solvent inlet filter, 20 µm pore size
1	5065-4426	Colored finger-tight PEEK fittings, 10/PK
3	5500-1193	Capillary ST 0.17 mm x 105 mm, long socket
1	5500-1217	Capillary ST 0.17 mm x 900 mm SI/SX ps-ps
2	5500-1246	Capillary ST 0.17 mm x 500 mm SI/SI
2	5500-1250	Capillary ST 0.17 mm x 120 mm SL/SL Long Socket
1	5959-3887	Ship Container
1	5971-5210	Assortment Box
1	8710-1930	Plastic tubing cutter
1	8710-2391	Rheotool socket wrench ¼ inch
1	5500-1191	Capillary ST 0.12 mm x 280 mm, long socket
6	G7167-68703	Fitting Intermediate Kit
1	G7111-90120	Technical Note 1260 Infinity II Max Uptime Kit

9 Parts for Maintenance

1260 Infinity II Low Dispersion Kit MCT

1260 Infinity II Low Dispersion Kit MCT

This kit will be sold optionally with the pump and is not essential for operation. You can reorder the individual parts.

p/n	Description
5500-1201	Capillary SST 0.12x105mm SL-- PS-LS
5500-1157	Capillary, ST, 0.12 mm x 500 mm
5959-3887	Ship Container
G7116-60015	Heat Exchanger Assembly 1.6 μ L-Z Quick Connect Heatexchanger Standard Flow
G7167-68703	Fitting Intermediate Kit
G7111-90130	1260 Infinity II Low Dispersion Kit MCT

HPLC System Tool Kit

HPLC System Tool Kit-Infinity-II (G7120-68708) contains the following items:

p/n	Description
0100-1681	Syringe adapter luer/barb
0100-1710	Mounting Tool for Tubing Connections
01018-23702	Insert tool
01080-83202	Blank nut (stainless steel)
5023-2524	Hex Key Set + Driver
5023-2500	Spanner double open ended SW-5
5023-2501	Screwdriver Torx-T10
5023-2502	Hex driver SW-6.35, slitted
5023-2503	Hex driver SW-5 slitted
5023-2504	Hex driver SW-4 slitted
8710-0510	Wrench open 1/4 — 5/16 inch
8710-0899	Pozidriv screwdriver
8710-1534	Wrench, 4 mm both ends, open end
8710-1924	Wrench open 14 mm
8710-2394	Hex key 9/64 inch 15 cm long T-handle
8710-2409	Wrench open end, 5/16 – 3/8 inch
8720-0025	Wrench, 1/2 inch & 9/16 inch
9301-0411	Syringe; Plastic
9301-1337	Syringe adapter

Solvent Cabinet

p/n	Description
5067-5760	Solvent Cabinet Kit

 $V_{\max} = 8.1 \text{ L}$

$$V_1 + V_2 + V_3 + \dots < V_{\max}$$

5067-5760

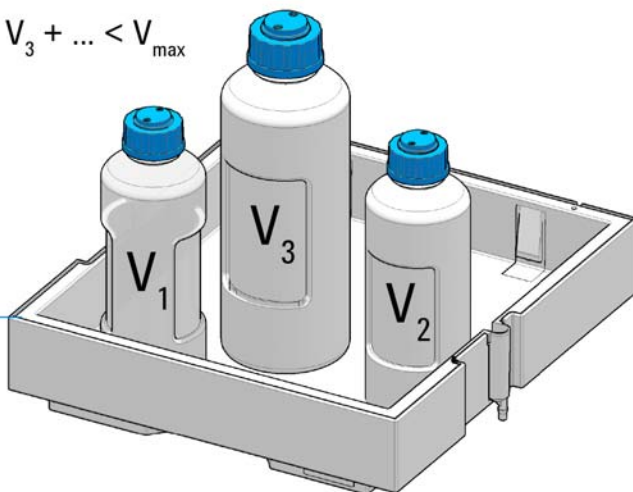

For details refer to: Usage Guideline for the Solvent Cabinet (01200-90150)

Bottle Head Assembly

p/n	Description
G7120-60007	Bottle Head Assembly
5063-6598	Ferrules with lock ring (10/Pk)
5063-6599	Tube screw (10/Pk)
	Wire marker
5062-2483	Tube PTFE 1.5 mm x 5 m, 3 mm od
5062-8517	Inlet filter adapter (4/Pk)
5041-2168	Solvent inlet filter, 20 µm pore size

Hydraulic Path of the Quaternary Pump



For bio-inert modules use bio-inert parts only!

Item	p/n	Description
1	G7111-81600	Capillary damper to inlet pump chamber
OR	G5654-81600	Capillary, Ti, damper to inlet valve for G5654A
OR 2	5067-5378	Connecting tube, MCGV to PIV
OR	G1311-67304	Connecting tube MCGV to AIV
3	G7111-60100	Solvent Tubes including labels (4x) for connection degasser to MCGV
4	G7111-81601	Capillary outlet valve to damper
OR	G5654-81601	Capillary, Ti, outlet valve to damper for G5654A
5	5062-2461	Waste tube, 5 m (reorder pack)
6	5500-1217	Capillary ST 0.17 mm x 900 mm SI/SX ps-ps Pump to Vialsampler with ICC
OR	5500-1246	Capillary ST 0.17 mm x 500 mm SI/SI
OR	5500-1264	Capillary Ti 0.17 mm x 500 mm SL/SLV for G5654A
	G7120-60007	Bottle Head Assembly (not shown)
	0100-1847	PEEK adapter 1/4-28 to 10-32 (Adapter AIV to solvent inlet tubes) (not shown)
	G1311-60006	Inline filter (OPTIONAL) (not shown) (OPTIONAL)

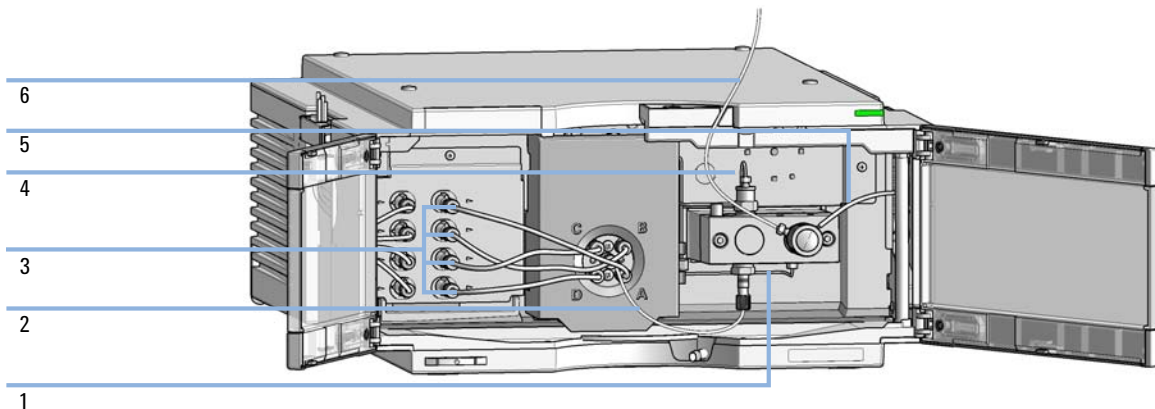

Figure 15 Hydraulic Flow Path of the Quaternary Pump

Hydraulic Path of the Isocratic Pump

Item	p/n	Description
1	G7111-81600	Capillary damper to inlet pump chamber
2	5500-1217	Capillary ST 0.17 mm x 900 mm SI/SX ps-ps Pump to Vialsampler with ICC
	5500-1246	Capillary ST 0.17 mm x 500 mm SI/SI
3	G7111-81601	Capillary outlet valve to damper
4	5062-2461	Waste tube, 5 m (reorder pack)
	G7120-60007	Bottle Head Assembly (not shown)
	G1311-60006	Inline filter (OPTIONAL) (not shown) (OPTIONAL)

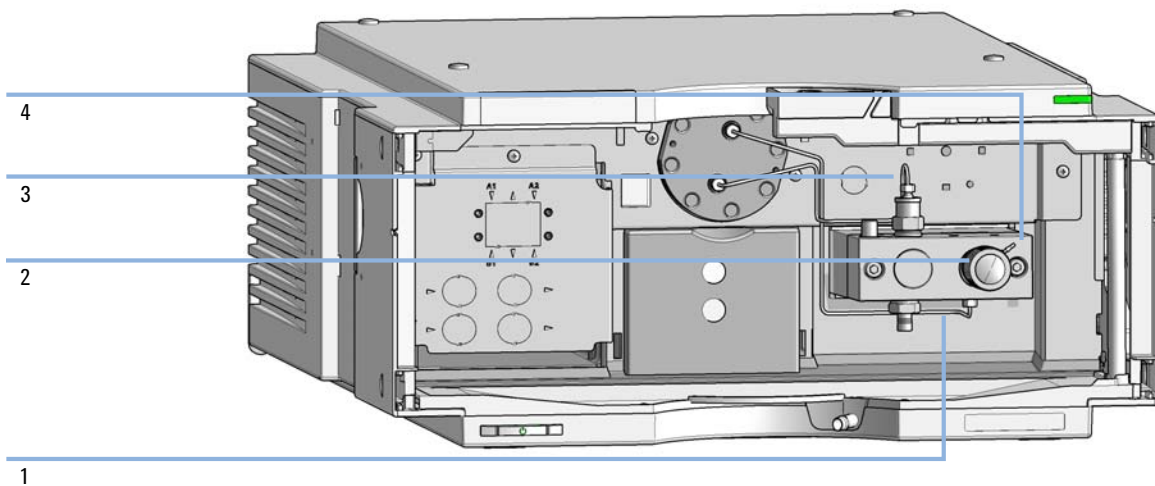
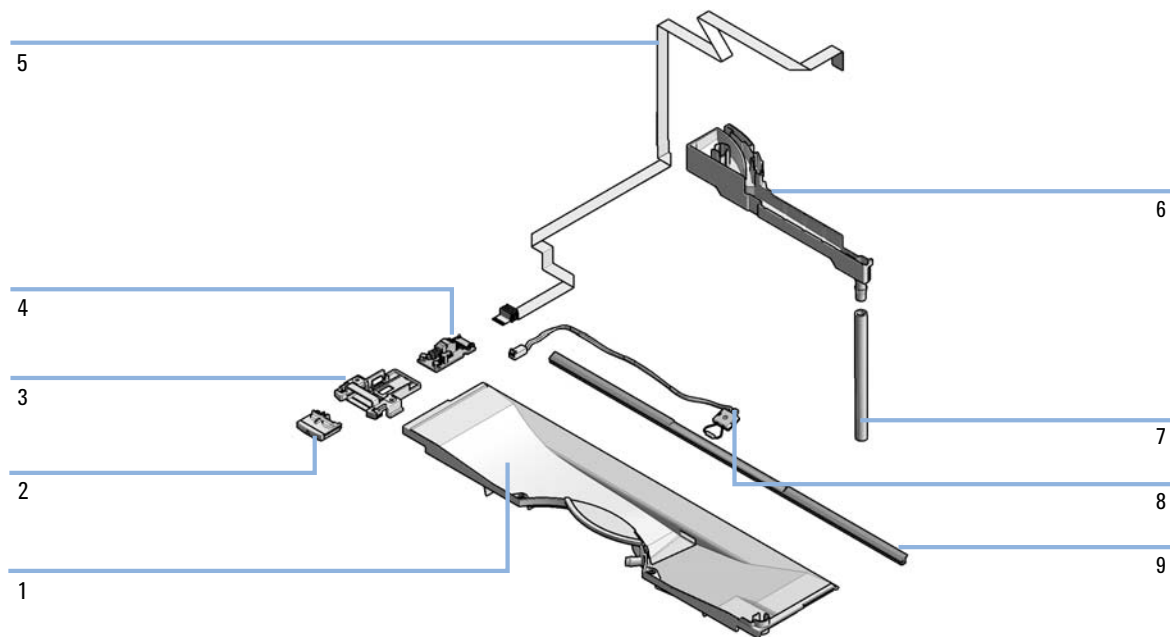

Figure 16 Hydraulic Flow Path of the Isocratic Pump

Leak Parts



Item	p/n	Description
1	5043-1053	Leak Plane
2-5	5067-5712	Power Switch Assy IF-II-HDI
6	5043-0856	Leak Adapter
7	5063-6527	Tubing assembly, i.d. 6 mm, o.d. 9 mm, 1.2 m (to waste)
8	5061-3356	Leak sensor
9	5043-1054	Leak Seal



10 Identifying Cables

Cable Overview	190
Analog Cables	192
Remote Cables	194
CAN Cable	198
Agilent Module to PC	199
Agilent 1200 Module to Printer	200

This chapter provides information on cables used with the Agilent 1200 Infinity Series modules.



Cable Overview

NOTE

Never use cables other than the ones supplied by Agilent Technologies to ensure proper functionality and compliance with safety or EMC regulations.

Analog cables

p/n	Description
35900-60750	Agilent 35900A A/D converter
01046-60105	Analog cable (BNC to general purpose, spade lugs)

Remote cables

p/n	Description
5188-8029	ERI to general purpose
5188-8044	Remote Cable ERI – ERI
5188-8045	Remote Cable APG – ERI
5061-3378	Remote Cable to 35900 A/D converter
01046-60201	Agilent module to general purpose

CAN cables

p/n	Description
5181-1516	CAN cable, Agilent module to module, 0.5 m
5181-1519	CAN cable, Agilent module to module, 1 m

LAN cables

p/n	Description
5023-0203	Cross-over network cable, shielded, 3 m (for point to point connection)
5023-0202	Twisted pair network cable, shielded, 7 m (for point to point connection)

**RS-232 cables
(not for FUSION
board)**

p/n	Description
G1530-60600	RS-232 cable, 2 m
RS232-61601	RS-232 cable, 2.5 m Instrument to PC, 9-to-9 pin (female). This cable has special pin-out, and is not compatible with connecting printers and plotters. It's also called "Null Modem Cable" with full handshaking where the wiring is made between pins 1-1, 2-3, 3-2, 4-6, 5-5, 6-4, 7-8, 8-7, 9-9.
5181-1561	RS-232 cable, 8 m

USB cables

p/n	Description
5188-8050	USB A M-USB Mini B 3 m (PC-Module)
5188-8049	USB A F-USB Mini B M OTG (Module to Flash Drive)

Analog Cables



One end of these cables provides a BNC connector to be connected to Agilent modules. The other end depends on the instrument to which connection is being made.

Agilent Module to 35900 A/D converters

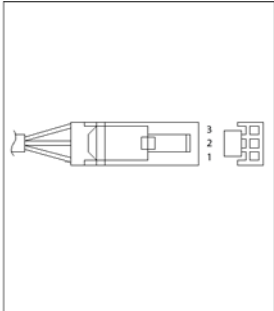
p/n 35900-60750	35900	Pin Agilent module	Signal Name
	1		Not connected
	2	Shield	Analog -
	3	Center	Analog +

Agilent Module to BNC Connector

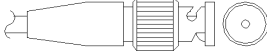
p/n 8120-1840	Pin BNC	Pin Agilent module	Signal Name
	Shield	Shield	Analog -
	Center	Center	Analog +

Agilent Module to General Purpose

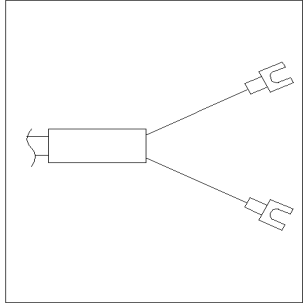
p/n 01046-60105	Pin	Pin Agilent module	Signal Name
	1		Not connected
	2	Black	Analog -
	3	Red	Analog +

10 Identifying Cables

Remote Cables

Remote Cables

ERI (Enhanced Remote Interface)

5188-8029 ERI to general purpose

p/n 5188-8029	pin	Color code	Enhanced Remote	Classic Remote	Active (TTL)
<p>D-Sub female 15way user's view to connector</p>	1	white	I01	START REQUEST	Low
	2	brown	I02	STOP	Low
	3	green	I03	READY	High
	4	yellow	I04	POWER ON	High
	5	grey	I05	NOT USED	
	6	pink	I06	SHUT DOWN	Low
	7	blue	I07	START	Low
	8	red	I08	PREPARE	Low
	9	black	1wire DATA		
	10	violet	DGND		
	11	grey-pink	+5V ERI out		
	12	red-blue	PGND		
	13	white-green	PGND		
	14	brown-green	+24V ERI out		
	15	white-yellow	+24V ERI out		
NC	yellow-brown				

5188-8044 ERI to ERI (Connector D_Subminiature 15 pin)

Table 21 5188-8044 ERI to ERI

p/n 5188-8044	Pin (ERI)	Signal	Pin (ERI)	Active (TTL)
	10	GND	10	
	1	Start Request	1	Low
	2	Stop	2	Low
	3	Ready	3	High
	5	Power on	5	High
	4	Future	4	
	6	Shut Down	6	Low
	7	Start	7	Low
	8	Prepare	8	Low
	Ground	Cable Shielding	NC	

5188-8045 ERI to APG (Connector D_Subminiature 15 pin (ERI), Connector D_Subminiature 9 pin (APG))

p/n 5188-8045	Pin (ERI)	Signal	Pin (APG)	Active (TTL)
	10	GND	1	
	1	Start Request	9	Low
	2	Stop	8	Low
	3	Ready	7	High
	5	Power on	6	High
	4	Future	5	
	6	Shut Down	4	Low
	7	Start	3	Low
	8	Prepare	2	Low
	Ground	Cable Shielding	NC	

10 Identifying Cables

Remote Cables



One end of these cables provides a Agilent Technologies APG (Analytical Products Group) remote connector to be connected to Agilent modules. The other end depends on the instrument to be connected to.

Agilent Module to Agilent 35900 A/D Converters

p/n 5061-3378	Pin 35900 A/D	Pin Agilent module	Signal Name	Active (TTL)
	1 - White	1 - White	Digital ground	
	2 - Brown	2 - Brown	Prepare run	Low
	3 - Gray	3 - Gray	Start	Low
	4 - Blue	4 - Blue	Shut down	Low
	5 - Pink	5 - Pink	Not connected	
	6 - Yellow	6 - Yellow	Power on	High
	7 - Red	7 - Red	Ready	High
	8 - Green	8 - Green	Stop	Low
	9 - Black	9 - Black	Start request	Low

Agilent Module to General Purpose

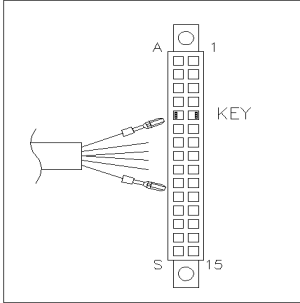
p/n 01046-60201	Wire Color	Pin Agilent module	Signal Name	Active (TTL)
	White	1	Digital ground	
	Brown	2	Prepare run	Low
	Gray	3	Start	Low
	Blue	4	Shut down	Low
	Pink	5	Not connected	
	Yellow	6	Power on	High
	Red	7	Ready	High
	Green	8	Stop	Low
	Black	9	Start request	Low

CAN Cable

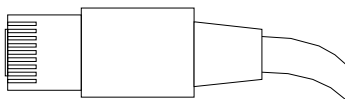

Both ends of this cable provide a modular plug to be connected to Agilent modules CAN or LAN connectors.

CAN Cables

p/n	Description
5181-1516	CAN cable, Agilent module to module, 0.5 m
5181-1519	CAN cable, Agilent module to module, 1 m

LAN Cables

p/n	Description
5023-0203	Cross-over network cable, shielded, 3 m (for point to point connection)
5023-0202	Twisted pair network cable, shielded, 7 m (for point to point connection)

Agilent Module to PC

p/n	Description
G1530-60600	RS-232 cable, 2 m
RS232-61601	RS-232 cable, 2.5 m Instrument to PC, 9-to-9 pin (female). This cable has special pin-out, and is not compatible with connecting printers and plotters. It's also called "Null Modem Cable" with full handshaking where the wiring is made between pins 1-1, 2-3, 3-2, 4-6, 5-5, 6-4, 7-8, 8-7, 9-9.
5181-1561	RS-232 cable, 8 m

10 Identifying Cables

Agilent 1200 Module to Printer

Agilent 1200 Module to Printer

To connect a USB Flash Drive use a USB OTG cable with Mini-B plug and A socket.

p/n	Description
5188-8050	USB A M-USB Mini B 3 m (PC-Module)
5188-8049	USB A F-USB Mini B M OTG (Module to Flash Drive)



11 Hardware Information

Firmware Description	202
Electrical Connections	205
Serial Number Information	206
Rear View of the Module	206
Interfaces	207
Overview Interfaces	208
ERI (Enhanced Remote Interface)	211
USB (Universal Serial Bus)	213
Setting the 6-bit Configuration Switch	214
Special Settings	216
Instrument Layout	218
Early Maintenance Feedback	219

This chapter describes the pump in more detail on hardware and electronics.



Firmware Description

The firmware of the instrument consists of two independent sections:

- a non-instrument specific section, called *resident system*
- an instrument specific section, called *main system*

Resident System

This resident section of the firmware is identical for all Agilent 1100/1200/1220/1260/1290 series modules. Its properties are:

- the complete communication capabilities (CAN, LAN, USB and RS- 232C)
- memory management
- ability to update the firmware of the 'main system'

Main System

Its properties are:

- the complete communication capabilities (CAN, LAN, USB and RS- 232C)
- memory management
- ability to update the firmware of the 'resident system'

In addition the main system comprises the instrument functions that are divided into common functions like

- run synchronization through APG remote,
- error handling,
- diagnostic functions,
- or module specific functions like
 - internal events such as lamp control, filter movements,
 - raw data collection and conversion to absorbance.

Firmware Updates

Firmware updates can be done using the following tools (latest version should be used):

- Agilent Lab Advisor software with files on the hard disk (*)
- Firmware Update Tool with local files on the hard disk (*)
- Instant Pilot (G4208A) with files on a USB Flash Disk

(*) Required tools, firmware and documentation are available from the Agilent web: <http://www.agilent.com/en-us/firmwareDownload?whid=69761>

The file naming conventions are:

PPPP_RVVV_XXX.dlb, where

PPPP is the product number, for example, 1315B for the G1315B DAD,

R the firmware revision, for example, A for G1315B or B for the G1315C DAD,

VVV is the revision number, for example 650 is revision 6.50,

XXX is the build number of the firmware.

For instructions on firmware updates refer to section *Replacing Firmware* in chapter "Maintenance" or use the documentation provided with the *Firmware Update Tools*.

NOTE

Update of main system can be done in the resident system only. Update of the resident system can be done in the main system only.

Main and resident firmware must be from the same set.

11 Hardware Information

Firmware Description

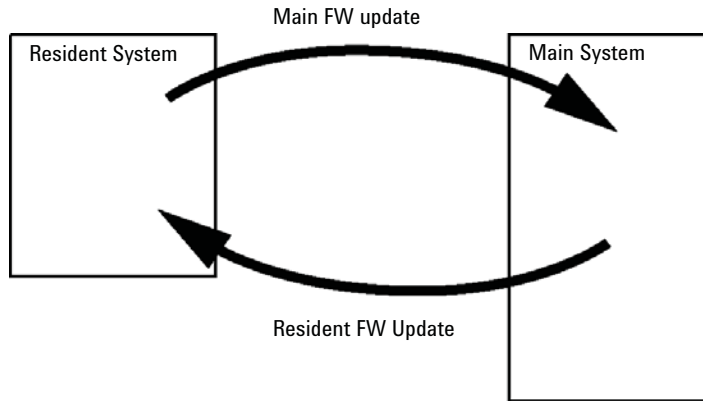

Figure 17 Firmware Update Mechanism

NOTE

Some modules are limited in downgrading due to their main board version or their initial firmware revision. For example, a G1315C DAD SL cannot be downgraded below firmware revision B.01.02 or to a A.xx.xx.

Some modules can be re-branded (e.g. G1314C to G1314B) to allow operation in specific control software environments. In this case the feature set of the target type are use and the feature set of the original are lost. After re-branding (e.g. from G1314B to G1314C), the original feature set is available again.

All these specific informations are described in the documentation provided with the firmware update tools.

The firmware update tools, firmware and documentation are available from the Agilent web.

- <http://www.agilent.com/en-us/firmwareDownload?whid=69761>

Electrical Connections

- The CAN bus is a serial bus with high-speed data transfer. The two connectors for the CAN bus are used for internal module data transfer and synchronization.
- One analog output provides signals for integrators or data handling systems.
- The ERI/REMOTE connector may be used in combination with other analytical instruments from Agilent Technologies if you want to use features such as start, stop, common shutdown, prepare, and so on.
- With the appropriate software, the LAN connector may be used to control the module from a computer through a LAN connection. This connector is activated and can be configured with the configuration switch.
- With the appropriate software, the USB connector may be used to control the module from a computer through a USB connection.
- The power input socket accepts a line voltage of 100 – 240 VAC \pm 10 % with a line frequency of 50 or 60 Hz. Maximum power consumption varies by module. There is no voltage selector on your module because the power supply has wide-ranging capability. There are no externally accessible fuses because automatic electronic fuses are implemented in the power supply.

NOTE

Never use cables other than the ones supplied by Agilent Technologies to ensure proper functionality and compliance with safety or EMC regulations.

Serial Number Information

The serial number information on the instrument labels provide the following information:

CCXZZ00000	Format
CC	Country of manufacturing <ul style="list-style-type: none">• DE = Germany• JP = Japan• CN = China
X	Alphabetic character A-Z (used by manufacturing)
ZZ	Alpha-numeric code 0-9, A-Z, where each combination unambiguously denotes a module (there can be more than one code for the same module)
00000	Serial number

Rear View of the Module

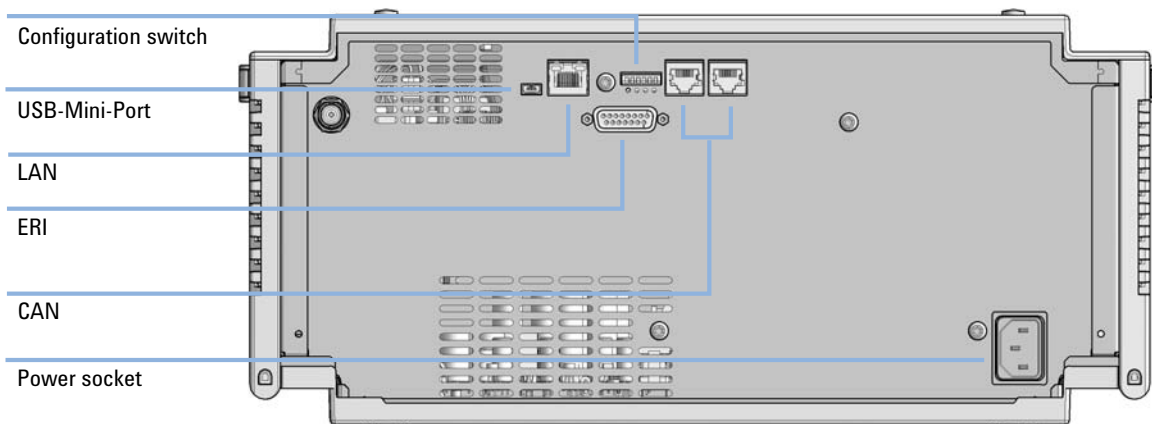

Figure 18 Rear view of the pump – electrical connections and label

Interfaces

The Agilent 1200 Infinity Series II modules provide the following interfaces:

Table 22 Agilent 1200 Infinity II Series Interfaces

Module	CAN	USB	LAN (on-board)	RS-232	Analog	APG (A) / ERI (E)	Special
Pumps							
G7104A Flexible Pump	2	No	Yes	Yes	1	A	
G7110B Isocratic Pump	2	Yes	Yes	No	No	E	
G7111A/B Quaternary Pump	2	Yes	Yes	No	No	E	
G7120A High Speed Pump	2	No	Yes	Yes	1	A	
Samplers							
G7129A/B ALS	2	Yes	Yes	No	No	E	
G7167A/B Multisampler	2	Yes	Yes	No	No	E	
Detectors							
G7114A/B VWD	2	Yes	Yes	No	1	E	
G7115A/B DAD	2	Yes	Yes	No	1	E	
G7117A/B/C DAD	2	Yes	Yes	No	1	E	
G7162A/B RID	2	Yes	Yes	No	1	E	
Others							
G7116A/B MCT	2	No	No	No	No	No	Requires a HOST module via CAN

NOTE

The detector (DAD/MWD/FLD/VWD/RID) is the preferred access point for control via LAN. The inter-module communication is done via CAN.

- CAN connectors as interface to other modules
- LAN connector as interface to the control software
- RS-232C as interface to a computer
- USB (Universal Series Bus) as interface to a computer
- REMOTE connector as interface to other Agilent products
- Analog output connector(s) for signal output

Overview Interfaces

CAN

The CAN is inter-module communication interface. It is a 2-wire serial bus system supporting high speed data communication and real-time requirement.

LAN

The modules have either an interface slot for an LAN card (e.g. Agilent G1369B/C LAN Interface) or they have an on-board LAN interface (e.g. detectors G1315C/D DAD and G1365C/D MWD). This interface allows the control of the module/system via a PC with the appropriate control software. Some modules have neither on-board LAN nor an interface slot for a LAN card (e.g. G1170A Valve Drive or G4227A Flex Cube). These are hosted modules and require a Host module with firmware B.06.40 or later or with additional G1369C LAN Card.

NOTE

If an Agilent detector (DAD/MWD/FLD/VWD/RID) is in the system, the LAN should be connected to the DAD/MWD/FLD/VWD/RID (due to higher data load). If no Agilent detector is part of the system, the LAN interface should be installed in the pump or autosampler.

USB

The USB interface replaces the RS-232 Serial interface in new FUSION generation modules. For details on USB refer to “[USB \(Universal Serial Bus\)](#)” on page 213.

Analog Signal Output

The analog signal output can be distributed to a recording device. For details refer to the description of the module's main board.

Remote (ERI)

The ERI (Enhanced Remote Interface) connector may be used in combination with other analytical instruments from Agilent Technologies if you want to use features as common shut down, prepare, and so on.

It allows easy connection between single instruments or systems to ensure coordinated analysis with simple coupling requirements.

The subminiature D connector is used. The module provides one remote connector which is inputs/outputs (wired- or technique).

To provide maximum safety within a distributed analysis system, one line is dedicated to **SHUT DOWN** the system's critical parts in case any module detects a serious problem. To detect whether all participating modules are switched on or properly powered, one line is defined to summarize the **POWER ON** state of all connected modules. Control of analysis is maintained by signal readiness **READY** for next analysis, followed by **START** of run and optional **STOP** of run triggered on the respective lines. In addition **PREPARE** and **START REQUEST** may be issued. The signal levels are defined as:

- standard TTL levels (0 V is logic true, + 5.0 V is false),
- fan-out is 10,
- input load is 2.2 kOhm against + 5.0 V, and
- output are open collector type, inputs/outputs (wired- or technique).

NOTE

All common TTL circuits operate with a 5 V power supply. A TTL signal is defined as "low" or L when between 0 V and 0.8 V and "high" or H when between 2.0 V and 5.0 V (with respect to the ground terminal).

Table 23 ERI signal distribution

Pin	Signal	Description
1	START REQUEST	(L) Request to start injection cycle (for example, by start key on any module). Receiver is the autosampler.
2	STOP	(L) Request to reach system ready state as soon as possible (for example, stop run, abort or finish and stop injection). Receiver is any module performing run-time controlled activities.
3	READY	(H) System is ready for next analysis. Receiver is any sequence controller.
4	POWER ON	(H) All modules connected to system are switched on. Receiver is any module relying on operation of others.
5		Not used
6	SHUT DOWN	(L) System has serious problem (for example, leak: stops pump). Receiver is any module capable to reduce safety risk.
7	START	(L) Request to start run / timetable. Receiver is any module performing run-time controlled activities.
8	PREPARE	(L) Request to prepare for analysis (for example, calibration, detector lamp on). Receiver is any module performing pre-analysis activities.

Special Interfaces

There is no special interface for this module.

ERI (Enhanced Remote Interface)

ERI replaces the AGP Remote Interface that is used in the HP 1090/1040/1050/1100 HPLC systems and Agilent 1100/1200/1200 Infinity HPLC modules. All new 1200 Infinity II products using the FUSION core electronics use ERI. This interface is already used in the Agilent Universal Interface Box 2 (UIB2)

ERI Description

The ERI interface contains eight individual programmable input/output pins. In addition, it provides 24 V power and 5 V power and a serial data line to detect and recognize further add-ons that could be connected to this interface. This way the interface can support various additional devices like sensors, triggers (in and out) and small controllers, etc.

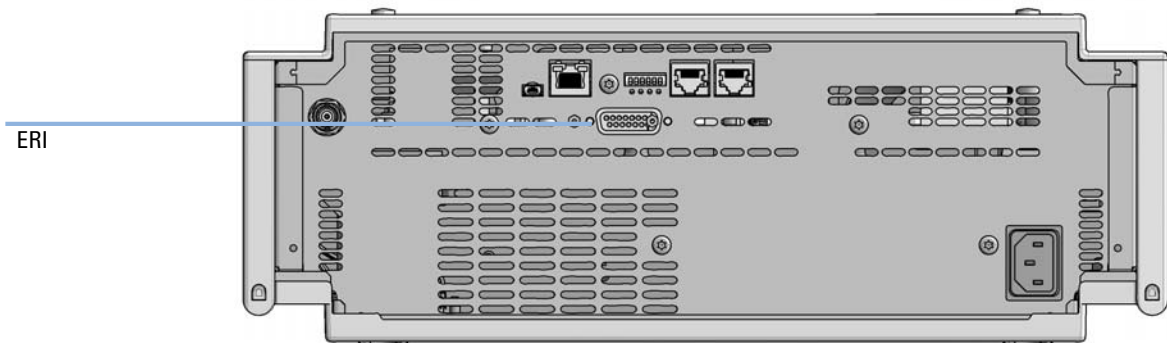

Figure 19 Location of the ERI interface (example shows a G7114A/B VWD)

11 Hardware Information

Interfaces

	Pin	Enhanced Remote
<p>D-Sub female 15way user's view to connector</p>	1	IO 1 (START REQUEST)
	2	IO 2 (STOP)
	3	IO 3 (READY)
	4	IO 4 (POWER ON)
	5	IO 5 (NOT USED)
	6	IO 6 (SHUT DOWN)
	7	IO 7 (START)
	8	IO 8 (PREPARE)
	9	1 wire DATA
	10	DGND
	11	+5 V ERI out
	12	PGND
	13	PGND
	14	+24 V ERI out
	15	+24 V ERI out

IO (Input/Output) Lines

- Eight generic bi-directional channels (input or output).
- Same as the APG Remote.
- Devices like valves, relays, ADCs, DACs, controllers can be supported/controlled.

1-Wire Data (Future Use)

This serial line can be used to read out an EPROM or write into an EPROM of a connected ERI-device. The firmware can detect the connected type of device automatically and update information in the device (if required).

5V Distribution (Future Use)

- Available directly after turn on of the hosting module (assures that certain base functionality of the device can be detected by firmware).
- For digital circuits or similar.
- Provided 500 mA maximum.
- Short-circuit proof with automatic switch off (by firmware).

24V Distribution (Future Use)

- Available by firmware command (defined turn on/off).
- For devices that need higher power
 - Class 0: 0.5 A maximum (12 W)
 - Class 1: 1.0 A maximum (24 W)
 - Class 2: 2.0 A maximum (48 W)
- Class depends on hosting module's internal power overhead.
- If a connected device requires more power the firmware detects this (overcurrent detection) and provides the information to the user interface.
- Fuse used for safety protection (on board).
- Short circuit will be detected through hardware.

USB (Universal Serial Bus)

USB (Universal Serial Bus) - replaces RS232, supports:

- a PC with control software (for example Agilent Lab Advisor)
- USB Flash Disk

Setting the 6-bit Configuration Switch

The 6-bit configuration switch is located at the rear of the module with FUSION electronics. Switch settings provide configuration parameters for LAN and instrument specific initialization procedures.

All modules with FUSION electronics:

- Default is ALL switches DOWN (best settings).
 - Default IP address for LAN 192.168.254.11
- For specific LAN modes switches 4-5 must be set as required.
- For boot resident/cold start modes switches 1+2 or 6 must be UP.

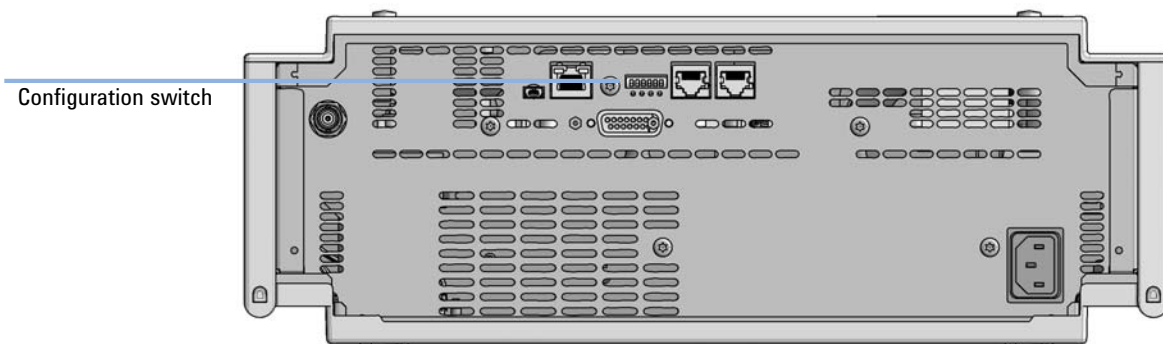

Figure 20 Location of Configuration switch (example shows a G7114A/B VWD)

Table 24 6-bit Configuration Switch

	Mode	Function/Setting				
	Switch 1	Switch 2	Switch 3	Switch 4	Switch 5	Switch 6
COM ¹	0	n.a. ²	n.a.	LAN Init Mode		n.a.
Use Default IP Address ³		0	0	0	0	0
Use Stored IP Address		0	0	0	1	0
Use DHCP to request IP Address ⁴		0	0	1	0	0
Test	1	System	n.a.	n.a.	n.a.	ColdStart
Boot Main System / Keep Data		0	0	0	0	0
Boot Resident System / Keep Data		1	0	0	0	0
Boot Main System / Revert to Default Data		0	0	0	0	1
Boot Resident System / Revert to Default Data		1	0	0	0	1

¹ When selecting mode COM, settings are stored to non-volatile memory. When selecting mode TEST, COM settings are taken from non-volatile memory.

² not assigned - Always keep these switches on position '0' (off)

³ Default IP Address is 192.168.254.11

⁴ Host Name will be the MAC address.

Special Settings

Boot-Resident/Main

Firmware update procedures may require this mode in case of firmware loading errors (main/resident firmware part).

If you use the following switch settings and power the instrument up again, the instrument firmware stays in the resident/main mode. In resident mode, it is not operable as a module. It only uses basic functions of the operating system for example, for communication. In this mode the main firmware can be loaded (using update utilities).

Forced Cold Start

A forced cold start can be used to bring the module into a defined mode with default parameter settings.

- **Boot Main System / Revert to Default Data**
The instrument will boot to main mode and changes to the module's default parameter. May be also required to load resident firmware into the module.
- **Boot Resident System / Revert to Default Data**
The instrument will boot to resident mode and changes to the module's default parameter. May be also required to load main firmware into the module.

CAUTION

Loss of data

Forced cold start erases all methods and data stored in the non-volatile memory. Exceptions are calibration settings, diagnosis and repair log books which will not be erased.

→ Save your methods and data before executing a forced cold start.

If you use the following switch settings and power the instrument up again, it will start as described above.

Table 25 Boot Resident / Forced Coldstart

	SW1	SW2	SW3	SW4	SW5	SW6	Init Mode
	1	0	0	0	0	0	Boot Main System / Keep Data
	1	1	0	0	0	0	Boot Resident System / Keep Data
	1	0	0	0	0	1	Boot Main System / Revert to Default Data
	1	1	0	0	0	1	Boot Resident System / Revert to Default Data

Note: The setting '0' (down) is essential.

Instrument Layout

The industrial design of the module incorporates several innovative features. It uses Agilent's E-PAC concept for the packaging of electronics and mechanical assemblies. This concept is based upon the use of expanded polypropylene (EPP) layers of foam plastic spacers in which the mechanical and electronic boards components of the module are placed. This pack is then housed in a metal inner cabinet which is enclosed by a plastic external cabinet. The advantages of this packaging technology are:

- virtual elimination of fixing screws, bolts or ties, reducing the number of components and increasing the speed of assembly/disassembly,
- the plastic layers have air channels molded into them so that cooling air can be guided exactly to the required locations,
- the plastic layers help cushion the electronic and mechanical parts from physical shock, and
- the metal inner cabinet shields the internal electronics from electromagnetic interference and also helps to reduce or eliminate radio frequency emissions from the instrument itself.

Early Maintenance Feedback

Maintenance requires the exchange of components which are subject to wear or stress. Ideally, the frequency at which components are exchanged should be based on the intensity of usage of the module and the analytical conditions, and not on a predefined time interval. The early maintenance feedback (**EMF**) feature monitors the usage of specific components in the instrument, and provides feedback when the user-selectable limits have been exceeded. The visual feedback in the user interface provides an indication that maintenance procedures should be scheduled.

EMF Counters

EMF counters increment with use and can be assigned a maximum limit which provides visual feedback in the user interface when the limit is exceeded. Some counters can be reset to zero after the required maintenance procedure.

Using the EMF Counters

The user-settable **EMF** limits for the **EMF Counters** enable the early maintenance feedback to be adapted to specific user requirements. The useful maintenance cycle is dependent on the requirements for use. Therefore, the definition of the maximum limits need to be determined based on the specific operating conditions of the instrument.

Setting the EMF Limits

The setting of the **EMF** limits must be optimized over one or two maintenance cycles. Initially the default **EMF** limits should be set. When instrument performance indicates maintenance is necessary, take note of the values displayed by the **EMF counters**. Enter these values (or values slightly less than the displayed values) as **EMF** limits, and then reset the **EMF counters** to zero. The next time the **EMF counters** exceed the new **EMF** limits, the **EMF** flag will be displayed, providing a reminder that maintenance needs to be scheduled.

11 Hardware Information

Early Maintenance Feedback



12 LAN Configuration

What You Have to Do First	222
TCP/IP parameter configuration	223
Configuration Switches	224
Initialization Mode Selection	225
Dynamic Host Configuration Protocol (DHCP)	227
General Information (DHCP)	227
Setup (DHCP)	228
Manual Configuration	230
With Telnet	231

This chapter provides information on connecting the module to the Agilent ChemStation PC.



What You Have to Do First

The module has an on-board LAN communication interface.

NOTE

This chapter is generic and may show figures that differ from your module. The functionality is the same.

- 1 Note the MAC (Media Access Control) address for further reference. The MAC or hardware address of the LAN interfaces is a world wide unique identifier. No other network device will have the same hardware address. The MAC address can be found on a label at the rear of the module underneath the configuration switch (see [Figure 22](#) on page 222).

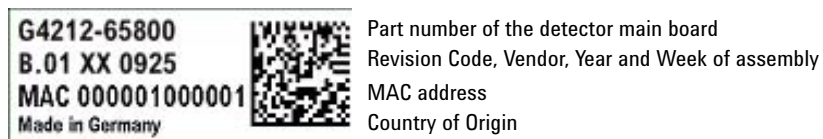

Figure 21 MAC-Label

- 2 Connect the instrument's LAN interface (see [Figure 22](#) on page 222) to
 - the PC network card using a crossover network cable (point-to-point) or
 - a hub or switch using a standard LAN cable.

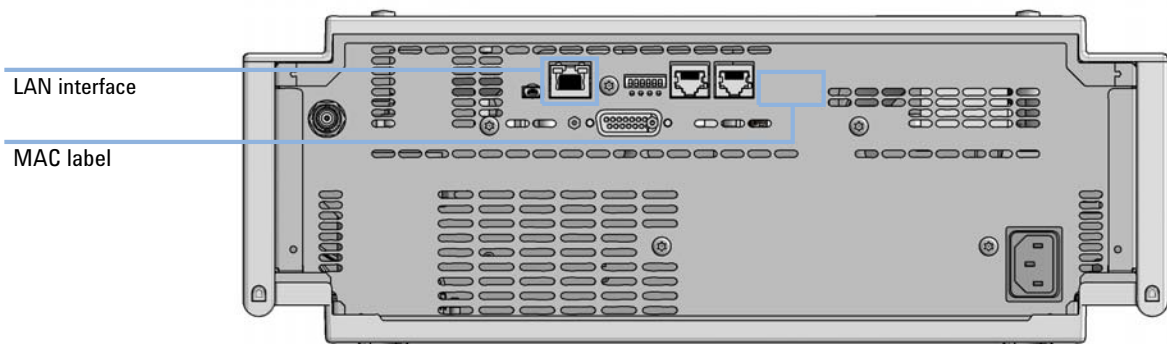

Figure 22 Location of LAN interfaces and MAC label

TCP/IP parameter configuration

To operate properly in a network environment, the LAN interface must be configured with valid TCP/IP network parameters. These parameters are:

- IP address
- Subnet Mask
- Default Gateway

The TCP/IP parameters can be configured by the following methods:

- by automatically requesting the parameters from a network-based DHCP Server (using the so-called Dynamic Host Configuration Protocol). This mode requires a LAN-onboard Module or a G1369C LAN Interface card, see [“Setup \(DHCP\)”](#) on page 228
- by manually setting the parameters using Telnet
- by manually setting the parameters using the Instant Pilot (G4208A)

The LAN interface differentiates between several initialization modes. The initialization mode (short form ‘init mode’) defines how to determine the active TCP/IP parameters after power-on. The parameters may be derived non-volatile memory or initialized with known default values. The initialization mode is selected by the configuration switch, see [Table 26](#) on page 225.

Configuration Switches

The configuration switch can be accessed at the rear of the module.

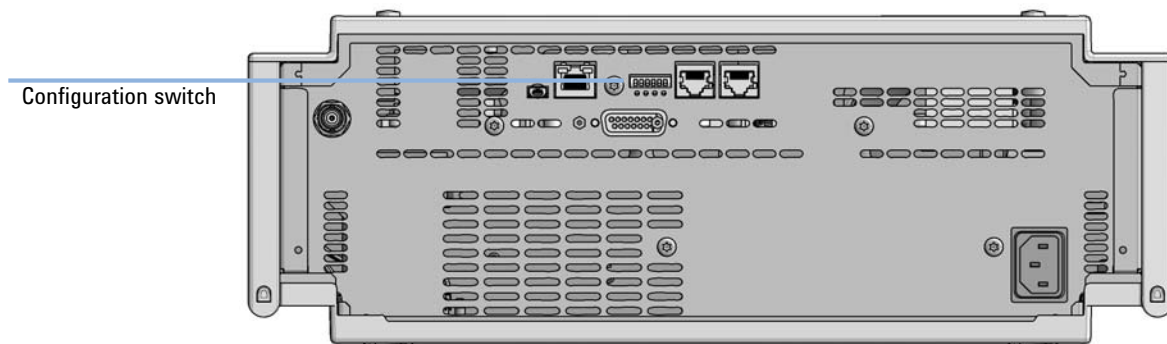

Figure 23 Location of Configuration switch (example shows a G7114A/B VWD)

The module is shipped with all switches set to OFF, as shown above.

NOTE

To perform any LAN configuration, SW1 and SW2 must be set to OFF.

Initialization Mode Selection

The following initialization (init) modes are selectable:

Table 26 Initialization Mode Switches

	SW1	SW2	SW3	SW4	SW5	SW6	Init Mode
	0	0	0	0	0	0	Use Default IP Address
	0	0	0	0	1	0	Use Stored IP Address
	0	0	0	1	0	0	Use DHCP

Note: The setting '0' (down) is essential.

Default IP address for LAN is 192.168.254.11.

DHCP address is the module's LAN MAC address.

Using Stored

When initialization mode **Using Stored** is selected, the parameters are taken from the non-volatile memory of the module. The TCP/IP connection will be established using these parameters. The parameters were configured previously by one of the described methods.

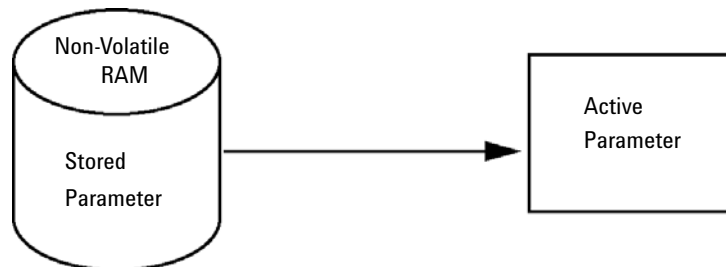

Figure 24 Using Stored (Principle)

Using Default

When **Using Default** is selected, the factory default parameters are taken instead. These parameters enable a TCP/IP connection to the LAN interface without further configuration, see [Table 27](#) on page 226.

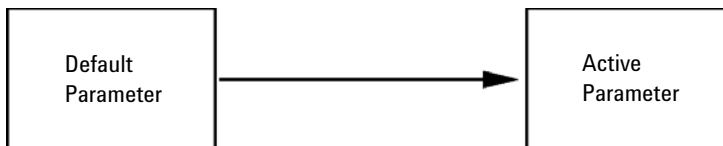

Figure 25 Using Default (Principle)

NOTE

Using the default address in your local area network may result in network problems. Take care and change it to a valid address immediately.

Table 27 Using Default Parameters

IP address:	192.168.254.11
Subnet Mask:	255.255.255.0
Default Gateway	not specified

Since the default IP address is a so-called local address, it will not be routed by any network device. Thus, the PC and the module must reside in the same subnet.

The user may open a Telnet session using the default IP address and change the parameters stored in the non-volatile memory of the module. He may then close the session, select the initialization mode **Using Stored**, power-on again and establish the TCP/IP connection using the new parameters.

When the module is wired to the PC directly (e.g. using a cross-over cable or a local hub), separated from the local area network, the user may simply keep the default parameters to establish the TCP/IP connection.

NOTE

In the **Using Default** mode, the parameters stored in the memory of the module are not cleared automatically. If not changed by the user, they are still available, when switching back to the mode **Using Stored**.

Dynamic Host Configuration Protocol (DHCP)

General Information (DHCP)

The Dynamic Host Configuration Protocol (DHCP) is an auto configuration protocol used on IP networks. The DHCP functionality is available on all Agilent HPLC modules with on-board LAN Interface or LAN Interface Card G1369C, and “B”-firmware (B.06.40 or above) or modules with "D"-firmware. All modules should use latest firmware from the same set.

When the initialization mode “DHCP” is selected, the card tries to download the parameters from a DHCP Server. The parameters obtained become the active parameters immediately. They are not stored to the non-volatile memory of the card.

Besides requesting the network parameters, the card also submits its hostname to the DHCP Server. The hostname equals the MAC address of the card, e.g. *0030d3177321*. It is the DHCP server's responsibility to forward the hostname/address information to the Domain Name Server. The card does not offer any services for hostname resolution (e.g. NetBIOS).

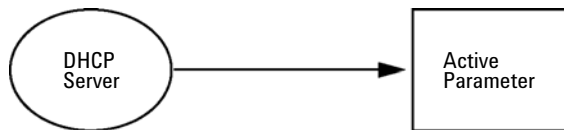

Figure 26 DHCP (Principle)

NOTE

- 1 It may take some time until the DHCP server has updated the DNS server with the hostname information.
- 2 It may be necessary to fully qualify the hostname with the DNS suffix, e.g. *0030d3177321.country.company.com*.
- 3 The DHCP server may reject the hostname proposed by the card and assign a name following local naming conventions.

12 LAN Configuration

Dynamic Host Configuration Protocol (DHCP)

Setup (DHCP)

The DHCP functionality is available on all Agilent HPLC modules with on-board LAN Interface or LAN Interface Card G1369C, and "B"-firmware (B.06.40 or above) or modules with "D"-firmware. All modules should use latest firmware from the same set.

- 1 Note the MAC address of the LAN interface (provided with G1369C LAN Interface Card or Main Board). This MAC address is on a label on the card or at the rear of the main board, e.g. *0030d3177321*.

On the Instant Pilot the MAC address can be found under **Details** in the LAN section.

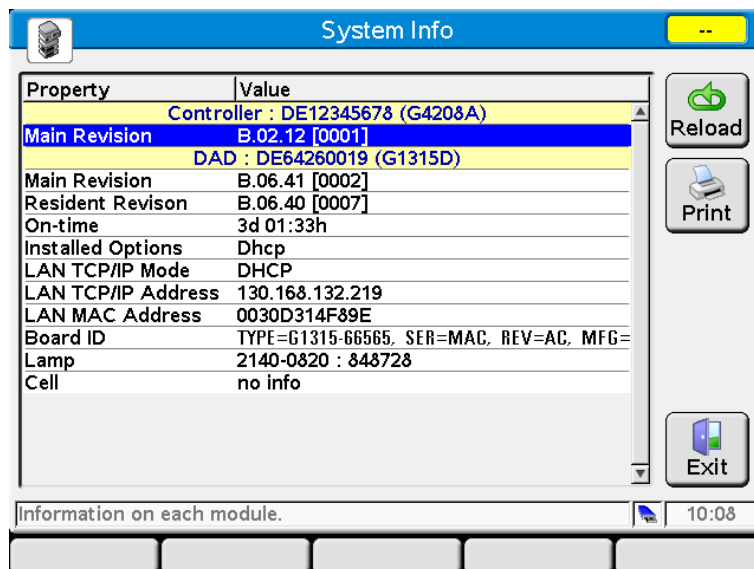

The screenshot shows the 'System Info' window with the following data:

Property	Value
Controller : DE12345678 (G4208A)	
Main Revision	B.02.12 [0001]
DAD : DE64260019 (G1315D)	
Main Revision	B.06.41 [0002]
Resident Revision	B.06.40 [0007]
On-time	3d 01:33h
Installed Options	Dhcp
LAN TCP/IP Mode	DHCP
LAN TCP/IP Address	130.168.132.219
LAN MAC Address	0030D314F89E
Board ID	TYPE=G1315-66565, SER=MAC, REV=AC, MFG=
Lamp	2140-0820 : 848728
Cell	no info

Buttons: Reload, Print, Exit

Information on each module. 10:08

Figure 27 LAN Setting on Instant Pilot

- 2 Set the Configuration Switch to DHCP either on the G1369C LAN Interface Card or the main board of above mentioned modules.

Table 28 G1369C LAN Interface Card (configuration switch on the card)

SW 4	SW 5	SW 6	SW 7	SW 8	Initialization Mode
ON	OFF	OFF	OFF	OFF	DHCP

Table 29 LC Modules with 8-bit configuration switch (B-firmware) (configuration switch at rear of the instrument)

SW 6	SW 7	SW 8	Initialization Mode
ON	OFF	OFF	DHCP

- 3 Turn on the module that hosts the LAN interface.
- 4 Configure your Control Software (e.g. OpenLAB CDS ChemStation Edition, Lab Advisor, Firmware Update Tool) and use MAC address as host name, e.g. *0030d3177321*.

The LC system should become visible in the control software (see Note in section “[General Information \(DHCP\)](#)” on page 227).

Manual Configuration

Manual configuration only alters the set of parameters stored in the non-volatile memory of the module. It never affects the currently active parameters. Therefore, manual configuration can be done at any time. A power cycle is mandatory to make the stored parameters become the active parameters, given that the initialization mode selection switches are allowing it.

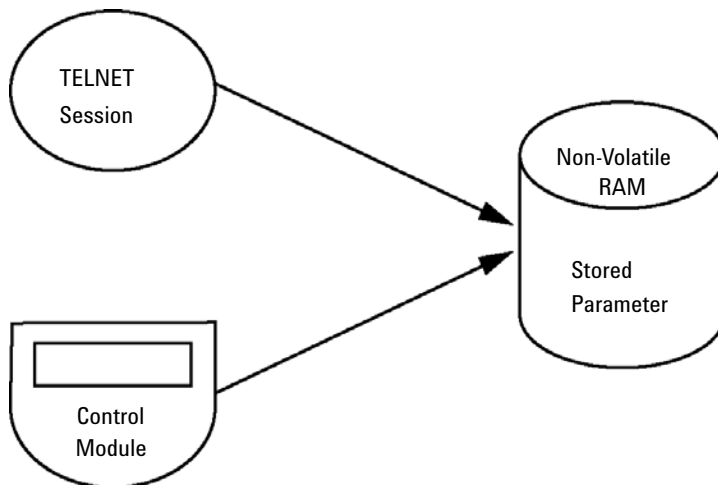
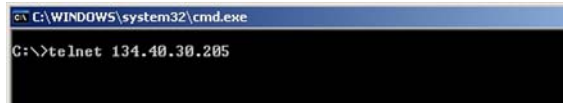

Figure 28 Manual Configuration (Principle)

With Telnet

Whenever a TCP/IP connection to the module is possible (TCP/IP parameters set by any method), the parameters may be altered by opening a Telnet session.

- 1 Open the system (DOS) prompt window by clicking on Windows **START** button and select **"Run..."**. Type "cmd" and press OK.
- 2 Type the following at the system (DOS) prompt:
 - `c:\>telnet <IP address> or`
 - `c:\>telnet <host name>`



```

C:\WINDOWS\system32\cmd.exe
C:\>telnet 134.40.30.205
    
```

Figure 29 Telnet - Starting a session

where <IP address> may be the assigned address from a Bootp cycle, a configuration session with the Handheld Controller, or the default IP address (see ["Configuration Switches"](#) on page 224).

When the connection was established successfully, the module responds with the following:

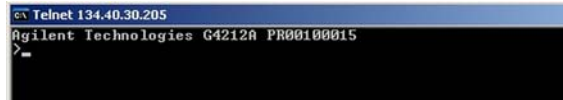

```

c\ Telnet 134.40.30.205
Agilent Technologies G4212A PR00100015
>
    
```

Figure 30 A connection to the module is made

- 3 Type `?` and press enter to see the available commands.

```
cx Telnet 134.40.30.205
Agilent Technologies G4212A PR00100015
>?
command syntax      description
-----
?                    display help info
/                    display current LAN settings
ip <x.x.x.x>         set IP Address
sm <x.x.x.x>         set Subnet Mask
gw <x.x.x.x>         set Default Gateway
exit                exit shell
>
```

Figure 31 Telnet Commands

Table 30 Telnet Commands

Value	Description
<code>?</code>	displays syntax and descriptions of commands
<code>/</code>	displays current LAN settings
<code>ip <x.x.x.x></code>	sets new ip address
<code>sm <x.x.x.x></code>	sets new subnet mask
<code>gw <x.x.x.x></code>	sets new default gateway
<code>exit</code>	exits shell and saves all changes

- 4 To change a parameter follows the style:

- parameter value, for example:
`ip 134.40.28.56`

Then press [Enter], where parameter refers to the configuration parameter you are defining, and value refers to the definitions you are assigning to that parameter. Each parameter entry is followed by a carriage return.

- 5 Use the “/” and press Enter to list the current settings.

```

c> Telnet 134.40.30.205
>/
LAN Status Page
-----
MAC Address   : 0030D317521C
Init Mode    : Using Stored
-----
TCP/IP Properties
- active -
IP Address   : 134.40.30.205
Subnet Mask  : 255.255.240.0
Def. Gateway : 134.40.24.1
-----
TCP/IP Status : Ready
Controllers  : no connections
>_
  
```

Figure 32 Telnet - Current settings in "Using Stored" mode

information about the LAN interface
MAC address, initialization mode
Initialization mode is Using Stored
active TCP/IP settings

TCP/IP status - here ready
connected to PC with controller software (e.g. Agilent
ChemStation), here not connected

- 6 Change the IP address (in this example 192.168.254.12) and type “/” to list current settings.

```

c> Telnet 134.40.30.205
>ip 192.168.254.12
>/
LAN Status Page
-----
MAC Address   : 0030D317521C
Init Mode    : Using Stored
-----
TCP/IP Properties
- active -
IP Address   : 134.40.30.205
Subnet Mask  : 255.255.240.0
Def. Gateway : 134.40.24.1
-----
- stored -
IP Address   : 192.168.254.12
Subnet Mask  : 255.255.240.0
Def. Gateway : 134.40.24.1
-----
TCP/IP Status : Ready
Controllers  : no connections
>_
  
```

Figure 33 Telnet - Change IP settings

change of IP setting to
Initialization mode is Using Stored
active TCP/IP settings

stored TCP/IP settings in non-volatile memory

connected to PC with controller software (e.g. Agilent
ChemStation), here not connected

12 LAN Configuration

Manual Configuration

- 7 When you have finished typing the configuration parameters, type **exit** and press **Enter** to exit with storing parameters.

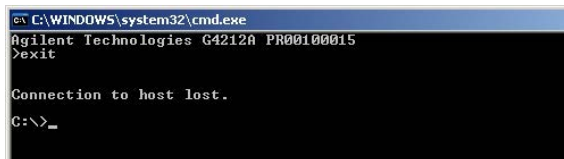

```
ca C:\WINDOWS\system32\cmd.exe
Agilent Technologies G4212A PR00100015
>exit

Connection to host lost.
C:\>_
```

Figure 34 Closing the Telnet Session

NOTE

If the Initialization Mode Switch is changed now to “Using Stored” mode, the instrument will take the stored settings when the module is re-booted. In the example above it would be 192.168.254.12.



13 Appendix

General Safety Information	236
General Safety Information	236
Safety Standards	236
General	236
Before Applying Power	237
Ground the Instrument	237
Do Not Operate in an Explosive Atmosphere	238
Do Not Remove the Instrument Cover	238
Do Not Modify the Instrument	238
In Case of Damage	238
Solvents	239
Safety Symbols	240
Waste Electrical and Electronic Equipment Directive	242
Radio Interference	243
Sound Emission	244
Agilent Technologies on Internet	245

This chapter provides addition information on safety, legal and web.



General Safety Information

General Safety Information

The following general safety precautions must be observed during all phases of operation, service, and repair of this instrument. Failure to comply with these precautions or with specific warnings elsewhere in this manual violates safety standards of design, manufacture, and intended use of the instrument. Agilent Technologies assumes no liability for the customer's failure to comply with these requirements.

WARNING

Ensure the proper usage of the equipment.

The protection provided by the equipment may be impaired.

→ The operator of this instrument is advised to use the equipment in a manner as specified in this manual.

Safety Standards

This is a Safety Class I instrument (provided with terminal for protective earthing) and has been manufactured and tested according to international safety standards.

General

Do not use this product in any manner not specified by the manufacturer. The protective features of this product may be impaired if it is used in a manner not specified in the operation instructions.

Before Applying Power

WARNING

Wrong voltage range, frequency or cabling

Personal injury or damage to the instrument

- Verify that the voltage range and frequency of your power distribution matches to the power specification of the individual instrument.
 - Never use cables other than the ones supplied by Agilent Technologies to ensure proper functionality and compliance with safety or EMC regulations.
 - Make all connections to the unit before applying power.
-

NOTE

Note the instrument's external markings described under “[Safety Symbols](#)” on page 240.

Ground the Instrument

WARNING

Missing electrical ground

Electrical shock

- If your product is provided with a grounding type power plug, the instrument chassis and cover must be connected to an electrical ground to minimize shock hazard.
 - The ground pin must be firmly connected to an electrical ground (safety ground) terminal at the power outlet. Any interruption of the protective (grounding) conductor or disconnection of the protective earth terminal will cause a potential shock hazard that could result in personal injury.
-

Do Not Operate in an Explosive Atmosphere

WARNING

Presence of flammable gases or fumes

Explosion hazard

→ Do not operate the instrument in the presence of flammable gases or fumes.

Do Not Remove the Instrument Cover

WARNING

Instrument covers removed

Electrical shock

→ Do Not Remove the Instrument Cover

→ Only Agilent authorized personnel are allowed to remove instrument covers. Always disconnect the power cables and any external circuits before removing the instrument cover.

Do Not Modify the Instrument

Do not install substitute parts or perform any unauthorized modification to the product. Return the product to an Agilent Sales and Service Office for service and repair to ensure that safety features are maintained.

In Case of Damage

WARNING

Damage to the module

Personal injury (for example electrical shock, intoxication)

→ Instruments that appear damaged or defective should be made inoperative and secured against unintended operation until they can be repaired by qualified service personnel.

Solvents

WARNING

Toxic, flammable and hazardous solvents, samples and reagents

The handling of solvents, samples and reagents can hold health and safety risks.

- When working with these substances observe appropriate safety procedures (for example by wearing goggles, safety gloves and protective clothing) as described in the material handling and safety data sheet supplied by the vendor, and follow good laboratory practice.
- Do not use solvents with an auto-ignition temperature below 200 °C (392 °F). Do not use solvents with a boiling point below 56 °C (133 °F).
- Avoid high vapor concentrations. Always keep the temperature in the sample compartment at least 25 K below the boiling point of the solvent used.
- Do not operate the instrument in an explosive atmosphere.
- Reduce the volume of substances to the minimum required for the analysis.
- Never exceed the maximum permissible volume of solvents (8 L) in the solvent cabinet. Do not use bottles that exceed the maximum permissible volume as specified in the usage guideline for solvent cabinet.
- Ground the waste container.
- Regularly check the filling level of the waste container. The residual free volume in the waste container must be large enough to collect the waste liquid.
- To achieve maximal safety, regularly check the tubing for correct installation.

NOTE

For details, see the usage guideline for the solvent cabinet. A printed copy of the guideline has been shipped with the solvent cabinet, electronic copies are available in the Agilent Information Center or via the Internet.

Safety Symbols

Table 31 Symbols













	The apparatus is marked with this symbol when the user should refer to the instruction manual in order to protect risk of harm to the operator and to protect the apparatus against damage.
	Indicates dangerous voltages.
	Indicates a protected ground terminal.
	The apparatus is marked with this symbol when hot surfaces are available and the user should not touch it when heated up.
	Cooling unit is designed as vapor-compression refrigeration system. Contains fluorinated greenhouse gas (refrigerant) according to the Kyoto protocol. For specifications of refrigerant, charge capacity, carbon dioxide equivalent (CDE), and global warming potential (GWP) see instrument label.
	Confirms that a manufactured product complies with all applicable European Community directives. The European Declaration of Conformity is available at: http://regulations.corporate.agilent.com/DoC/search.htm
	Manufacturing date.
	Power symbol indicates On/Off. The apparatus is not completely disconnected from the mains supply when the power switch is in the Off position
	Pacemaker Magnets could affect the functioning of pacemakers and implanted heart defibrillators. A pacemaker could switch into test mode and cause illness. A heart defibrillator may stop working. If you wear these devices keep at least 55 mm distance to magnets. Warn others who wear these devices from getting too close to magnets.

Table 31 Symbols

	<p>Magnetic field Magnets produce a far-reaching, strong magnetic field. They could damage TVs and laptops, computer hard drives, credit and ATM cards, data storage media, mechanical watches, hearing aids and speakers. Keep magnets at least 25 mm away from devices and objects that could be damaged by strong magnetic fields.</p>
	<p>Indicates a pinching or crushing hazard</p>
	<p>Indicates a piercing or cutting hazard.</p>

WARNING

A WARNING

alerts you to situations that could cause physical injury or death.

- Do not proceed beyond a warning until you have fully understood and met the indicated conditions.

CAUTION

A CAUTION

alerts you to situations that could cause loss of data, or damage of equipment.

- Do not proceed beyond a caution until you have fully understood and met the indicated conditions.

Waste Electrical and Electronic Equipment Directive

Abstract

The Waste Electrical and Electronic Equipment (WEEE) Directive (2002/96/EC), adopted by EU Commission on 13 February 2003, is introducing producer responsibility on all electric and electronic appliances starting with 13 August 2005.

NOTE

This product complies with the WEEE Directive (2002/96/EC) marking requirements. The affixed label indicates that you must not discard this electrical/electronic product in domestic household waste.

Product Category:

With reference to the equipment types in the WEEE Directive Annex I, this product is classed as a Monitoring and Control Instrumentation product.



NOTE

Do not dispose of in domestic household waste

To return unwanted products, contact your local Agilent office, or see <http://www.agilent.com> for more information.

Radio Interference

Cables supplied by Agilent Technologies are screened to provide optimized protection against radio interference. All cables are in compliance with safety or EMC regulations.

Test and Measurement

If test and measurement equipment is operated with unscreened cables, or used for measurements on open set-ups, the user has to assure that under operating conditions the radio interference limits are still met within the premises.

Sound Emission

Manufacturer's Declaration

This statement is provided to comply with the requirements of the German Sound Emission Directive of 18 January 1991.

This product has a sound pressure emission (at the operator position) < 70 dB.

- Sound Pressure $L_p < 70$ dB (A)
- At Operator Position
- Normal Operation
- According to ISO 7779:1988/EN 27779/1991 (Type Test)

Agilent Technologies on Internet

For the latest information on products and services visit our worldwide web site on the Internet at:

<http://www.agilent.com>

Index

1

- 1260 Infinity II low dispersion kit 180
- 1260 Infinity II max uptime kit 179

A

- accessory kit 170
- active inlet valve cartridge 164
- active inlet valve 164, 178
- active seal wash 10, 86
- adapter 164
- Agilent Lab Advisor software 93
- Agilent Lab Advisor 93
- Agilent
 - on internet 245
- AIV fuse 107
- algae growth 80
- alternative seal material 87
- ambient non-operating temperature 37, 38, 39, 40
- ambient operating temperature 37, 38, 39, 40
- analog signal 209
- AUTO mode 26

B

- ball-screw drive 22
- bench space 36
- bio-inert
 - materials 72
- blockage 109
- bottle head assembly 183
- buffer application 58
- buffer solution 10, 161

C

- cable
 - CAN 198
 - LAN 198
 - overview 190
 - RS-232 199
 - cables
 - analog 192
 - remote 194
 - CAN
 - cable 198
 - cleaning 137
 - compensation sensor open 102
 - compensation sensor short 102
 - composition precision 43, 45, 47
 - composition range 43, 45, 47
 - compressibility compensation 25, 41, 43, 45, 47, 88
 - condensation 36
 - configuration switch 224
- ## D
- degasser limit not reached 116
 - degasser signal fail 116
 - degasser, when to use 84
 - delay volume 43, 45
 - DHCP
 - general information 227
 - setup 228
 - dimensions 37, 38, 39, 40
 - doors
 - install 138, 138
 - remove 138, 138
 - dual-piston in-series design 19

E

- electrical connections
 - descriptions of 205
- electronic waste 242
- EMF
 - early maintenance feedback 219
- error messages, degasser limit not reached 116
- error messages, degasser signal fail 116
- error messages
 - AIV fuse 107
 - compensation sensor open 102
 - compensation sensor short 102
 - fan failed 103
 - ignition without cover 103, 103
 - index adjustment 113
 - index limit 112
 - index missing 113
 - initialization failed 114
 - leak sensor open 101
 - leak sensor short 101
 - leak 100
 - lost CAN partner 100
 - MCGV fuse 107
 - motor-drive power 109
 - pressure above upper limit 105
 - pressure below lower limit 106
 - pressure signal missing 106
 - pump error 105
 - pump head missing 112
 - remote timeout 99
 - servo restart failed 111
 - shutdown 99
 - solvent zero counter 105
 - temperature limit exceeded 110

- timeout 98
- valve failed 108
- wait timeout 115
- exchanging
 - active inlet valve cartridge 164
 - active inlet valve 164
 - multi channel gradient valve (MCGV) 161
 - outlet valve 142
 - passive inlet valve 140
 - purge valve frit 144
 - purge valve 144
 - seal wash cartridge 166
- F**
- fan failed 103
- firmware
 - description 202
 - main system 202
 - resident system 202
 - update tool 203
 - updates 203, 168
 - upgrade/downgrade 168
- flow accuracy 41, 43, 45, 47
- flow precision 41, 43, 45, 47
- flow range 41, 43, 45
- frequency range 37, 38, 39, 40
- G**
- general error messages 98
- gradient formation 43, 45, 47
- gradient valve 161
- H**
- hints for successful use 58
- humidity 37, 38, 39, 40
- hydraulic path
 - isocratic pump 186
 - quaternary pump 184
- hydraulic system 41, 43, 45, 47
- I**
- index adjustment 113
- index limit 112
- index missing 113
- initialization failed 114
- initialization 24
- inlet valve
 - passive 140
- installation
 - bench space 36
- installing
 - pump head assembly 158
- install
 - doors 138
- instrument layout 218
- interfaces
 - Infinity II 207
- internet 245
- introduction to the pump 10
- L**
- LAN
 - cable 198
 - configuration switche 224
 - manual configuration with telnet 231
 - manual configuration 230
 - TCP/IP parameter configuration 223
 - using default 226
 - using stored 225
 - what you have to do first 222, 222
- leak parts
 - replace 167
- leak rate test
 - evaluating results 129
 - running the test 128
- leak sensor open 101
- leak sensor short 101
- leak system
 - parts 188
- leak 100
- line frequency 37, 38, 39, 40
- line voltage 37, 38, 39, 40
- lost CAN partner 100
- M**
- MAC
 - address 222
- maintenance
 - feedback 219
 - overview 136
 - pump head with seal wash 154
 - pump head without seal wash 151
 - replacing firmware 168
- manual configuration
 - of LAN 230
- materials
 - bio-inert 72
- MCGV fuse 107
- MCGV 19
- message
 - ignition without cover 103, 103
 - remote timeout 99
- module firmware
 - replace 168
- motor-drive power 109
- multi channel gradient valve (MCGV) 161
- N**
- non-operating altitude 37, 38, 39, 40
- non-operating temperature 37, 38, 39, 40
- normal phase 81
 - seals 82

Index

O

operating Altitude 37, 38, 39, 40
operating temperature 37, 38, 39, 40
operational hints, MCGV 85
operational pressure range 41, 43, 45
outlet valve 142, 176
overview, pump 19
overview
cable 190

P

parts identification
cables 189
parts
1260 Infinity II low dispersion
kit 180
1260 Infinity II max uptime kit 179
accessory kit 170
active inlet valve 178
bottle head assembly 183
hydraulic path 186, 184
leak system 188
outlet valve 176
pump head with seal wash 174
pump head without seal wash 172
purge valve assembly 177
solvent cabinet 182
passive inlet valve
exchanging 140
pH range 43, 45, 47
physical specifications 37, 38, 39, 40
piston chamber 19
piston 22, 58
power consideration 34
power consumption 37, 38, 39, 40
power cords 35
pressure above upper limit 105
pressure below lower limit 106

pressure pulsation 26, 41, 43, 45, 47, 88
pressure range 87
pressure signal missing 106
pressure, operating range 41, 43, 45
proportioning valve, high-speed 19
pump error messages 105
pump head assembly
no seal wash 172
seal wash 174
pump head missing 112
pump head
with seal wash 154
without seal wash 151
pump piston 58
pump
isocratic 11
quaternary VL 15, 13
quaternary 17
purge valve assembly 177
purge valve frit 58, 144
purge valve 144
o-ring 148

R

radio interference 243
recommended pH range 43, 45, 47
remote (ERI) 209
remote
cables 194
remove
doors 138
removing
pump head assembly 149
repairs
replacing firmware 168
replace
leak parts 167
replacing

o-ring of purge valve 148
RS-232C
cable 199

S

safety class I 236
safety
general information 236
standards 38, 37, 40, 39
symbols 240
sapphire piston 22
seal wash cartridge 166
seal wash 10, 86
when to use 86
seal, alternative material 87
seal
wear-in 160
serial number
information 206
servo restart failed 111
setable flow range 41, 43, 45, 47
shutdown 99
simple repairs 134
site requirements
power cords 35
solvent cabinet 58, 182
solvent filter
checking 139
replacing 139
solvent filters
prevent blocking 80
solvent inlet filters 58
solvent zero counter 105
sound emission 244
special interfaces 210
special settings
boot main 216
boot-resident 216
specification

- physical 38, 37, 40, 39
- stroke volume 22, 26
- system pressure test, evaluating results 124
- system pressure test 121
 - running the test 123

T

- TCP/IP parameter configuration 223
- telnet
 - configuration 231
- temperature limit exceeded 110
- temperature sensor 100
- timeout 98
- troubleshooting
 - error messages 97

U

- USB 208
- user interfaces 92

V

- vacuum degasser 10, 42, 46
- valve failed 108
- variable reluctance motor 22
- variable stroke volume 26
- voltage range 37, 38, 39, 40

W

- wait timeout 115
- waste
 - electrical and electronic equipment 242
- wear-in
 - procedure 160
- WEEE directive 242
- weight 37, 38, 39, 40

In This Book

This manual contains technical information about the Agilent 1260 Infinity II Isocratic Pump (G7110B), the Agilent 1260 Infinity II Quaternary Pump VL (G7111A), the Agilent 1260 Infinity II Quaternary Pump (G7111B), and the Agilent 1260 Infinity II Bio-inert Pump (G5654A).

The manual describes the following:

- introduction,
- site requirements and specifications,
- using the pump,
- optimizing performance,
- troubleshooting and diagnostics,
- maintenance,
- parts and materials for maintenance,
- identifying cables,
- hardware information,
- appendix.

© Agilent Technologies 2016

Printed in Germany
04/2016



G7111-90000



Agilent Technologies